

INSTALLATION MANUAL

SUNLINE 2000™ SINGLE PACKAGE HEAT PUMP

BQ 036, 048 & 060

EXPORT ONLY

CONTENTS

GENERAL	4
SAFETY CONSIDERATIONS	4
INSPECTION	4
REFERENCE	4
RENEWAL PARTS	4
APPROVALS	4
PRODUCT NOMENCLATURE	5
INSTALLATION	6
OPERATION	31
START-UP (COOLING)	35
TROUBLESHOOTING	35
MAINTENANCE	38

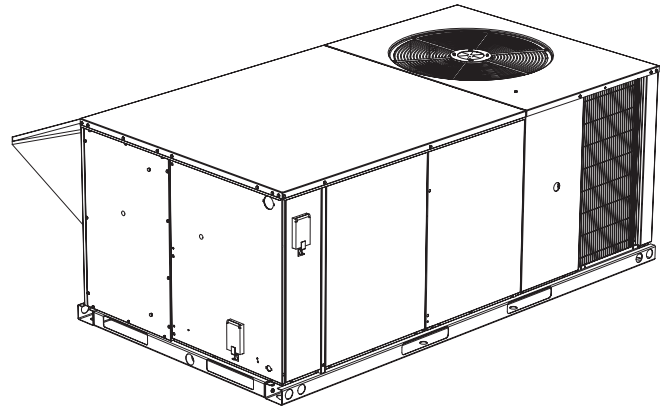

See the following page for a complete Table of Contents.

NOTES, CAUTIONS AND WARNINGS

The installer should pay particular attention to the words: *NOTE*, *CAUTION*, and *WARNING*. Notes are intended to clarify or make the installation easier. Cautions are given to prevent equipment damage. Warnings are given to alert installer that personal injury and/or equipment damage may result if installation procedure is not handled properly.

CAUTION: READ ALL SAFETY GUIDES BEFORE YOU BEGIN TO INSTALL YOUR UNIT.

SAVE THIS MANUAL



ISO 9001
Certified Quality
Management System

TABLE OF CONTENTS

GENERAL	4	COOLING SEQUENCE OF OPERATION	31
SAFETY CONSIDERATIONS	4	CONTINUOUS BLOWER	31
INSPECTION	4	INTERMITTENT BLOWER	31
REFERENCE	4	NO OUTDOOR AIR OPTIONS	31
RENEWAL PARTS	4	ECONOMIZER WITH SINGLE ENTHALPY SENSOR -	32
APPROVALS	4	ECONOMIZER WITH DUAL ENTHALPY SENSORS -	32
PRODUCT NOMENCLATURE	5	ECONOMIZER (SINGLE OR DUAL) WITH POWER EXHAUST -	32
INSTALLATION	6	MOTORIZED OUTDOOR AIR DAMPERS -	32
INSTALLATION SAFETY INFORMATION:	6	COOLING OPERATION ERRORS	32
LIMITATIONS	6	HIGH-PRESSURE LIMIT SWITCH	32
LOCATION	6	LOW-PRESSURE LIMIT SWITCH	32
RIGGING AND HANDLING	7	FREEZESTAT	32
CLEARANCES	7	LOW AMBIENT COOLING	33
DUCTWORK	7	SAFETY CONTROLS	33
CONDENSATE DRAIN	7	COMPRESSOR PROTECTION	33
COMPRESSORS	8	FLASH CODES	33
FILTERS	8	RESET	33
SERVICE ACCESS	8	HEATING SEQUENCE OF OPERATIONS	33
THERMOSTAT	10	WITH OR WITHOUT ELECTRIC HEAT	33
POWER AND CONTROL WIRING	10	DEFROST MODE	34
OPTIONS/ACCESSORIES	10	FORCED DEFROST	34
ELECTRIC HEAT	10	SAFETY CONTROLS	34
ECONOMIZER/MOTORIZED DAMPER AND RAIN HOOD	11	HEAT ANTICIPATOR SETPOINTS	34
POWER EXHAUST/BAROMETRIC RELIEF DAMPER AND RAIN HOOD	11	START-UP (COOLING)	35
ECONOMIZER AND POWER EXHAUST DAMPER SET POINT ADJUSTMENTS AND INFORMATION	11	PRESTART CHECK LIST	35
MINIMUM POSITION ADJUSTMENT	12	OPERATING INSTRUCTIONS	35
ENTHALPY SET POINT ADJUSTMENT	12	POST START CHECK LIST	35
POWER EXHAUST DAMPER SETPOINT (WITH OR WITHOUT POWER EXHAUST)	12	SHUT DOWN	35
INDOOR AIR QUALITY	12	TROUBLESHOOTING	35
PHASING	30	COOLING TROUBLESHOOTING GUIDE	35
SUPPLY AIR BLOWERS	30	UNIT FLASH CODES	37
CHECKING SUPPLY AIR CFM	30	MAINTENANCE	38
OPERATION	31	NORMAL MAINTENANCE	38
SEQUENCE OF OPERATIONS OVERVIEW	31	FILTERS	38
		MOTORS	38
		OUTDOOR COIL	38

LIST OF FIGURES

<u>Fig. #</u>	<u>Pg. #</u>
1	7
2	8
3	9
4	13
5	13
6	14
7	22
8	23
9	23
10	24
11	24
12	30
13	31

LIST OF TABLES

<u>Tbl. #</u>	<u>Pg. #</u>
1	6
2	10
3	11
4	14
5	14
6	14
7	15
8	15
9	16
10	17
11	18

<u>Tbl. #</u>	<u>Pg. #</u>
12	19
13	20
14	21
15	22
16	22
17	24
18	24
19	25
20	25
21	25
22	25
23	26
24	26
25	26
26	27
27	27
28	27
29	27
30	34
31	35
32	37

GENERAL

YORK Model BQ units are single package heat pumps equipped with optional factory installed electric heaters. These are designed for outdoor installation on a rooftop or slab.

The units are completely assembled on rigid, permanently attached base rails. All piping, refrigerant charge, and electrical wiring is factory installed and tested. The units require electric power, gas connection, duct connections, installation of combustion air inlet hood, flue gas outlet hoods and fixed outdoor air intake damper (units without economizer or motorized damper option only) at the point of installation.

The supplemental electric heaters have nickel-chrome elements and utilize single point power connection.

SAFETY CONSIDERATIONS

Due to system pressure, moving parts and electrical components, installation and servicing of air conditioning equipment can be hazardous. Only qualified, trained, service personnel should install, repair, maintain or service this equipment.

Observe all precautions in the literature, on labels and tags accompanying the equipment whenever working on air conditioning equipment. Be sure to follow all other safety precautions that apply.

Wear safety glasses and work gloves, and follow all safety codes. Use a quenching cloth and have a fire extinguisher available for all brazing operations.

INSPECTION

As soon as a unit is received, it should be inspected for possible damage during transit. If damage is evident, the extent of the damage should be noted on the carrier's freight bill. A separate request for inspection by the carrier's agent should be made in writing. Refer to Form 50.15-NM for additional information.

REFERENCE

Additional information on the design, installation, operation and service of this equipment is available in the following reference forms:

- 364985 -General Installation
- 035-19404-000 -Economizer Accessory
- 530.18-N1.13V -Man. Outdoor Air Damper Accessory 0 - 35%

- 530.18-N1.14V -Man. Outdoor Air Damper Accy 0 - 100%
- 035-07364-000 -Motorized Outdoor Air Damper Accy.
- 035-19422-000 -Electric Heat Accessory
- 035-19405-000 -Barometric Relief Damper
- 530.46-N1.1V -Dual Enthalpy Accessory
- 530.18-N1.10V -Power Exhaust Accessory

RENEWAL PARTS

Contact your local York® parts distribution center for authorized replacement parts.

APPROVALS

Design listed by CSA as follows:

- For use as a heat pump only with or without optional electric heat.
- For outdoor installation only.
- For installation on combustible material.

CAUTION

This product must be installed in strict compliance with the enclosed installation instructions and any applicable local, state, and national codes including, but not limited to, building, electrical, and mechanical codes.

WARNING

Improper installation may create a condition where the operation of the product could cause personal injury or property damage.

The installer should pay particular attention to the words: NOTE, CAUTION and WARNING. Notes are intended to clarify or make the installation easier. Cautions are given to prevent equipment damage. Warnings are given to alert installer that personal injury and/or equipment damage may result if installation procedure is not handled properly.

PRODUCT NOMENCLATURE

3-5 Ton Sunline Simplicity Model Number Nomenclature

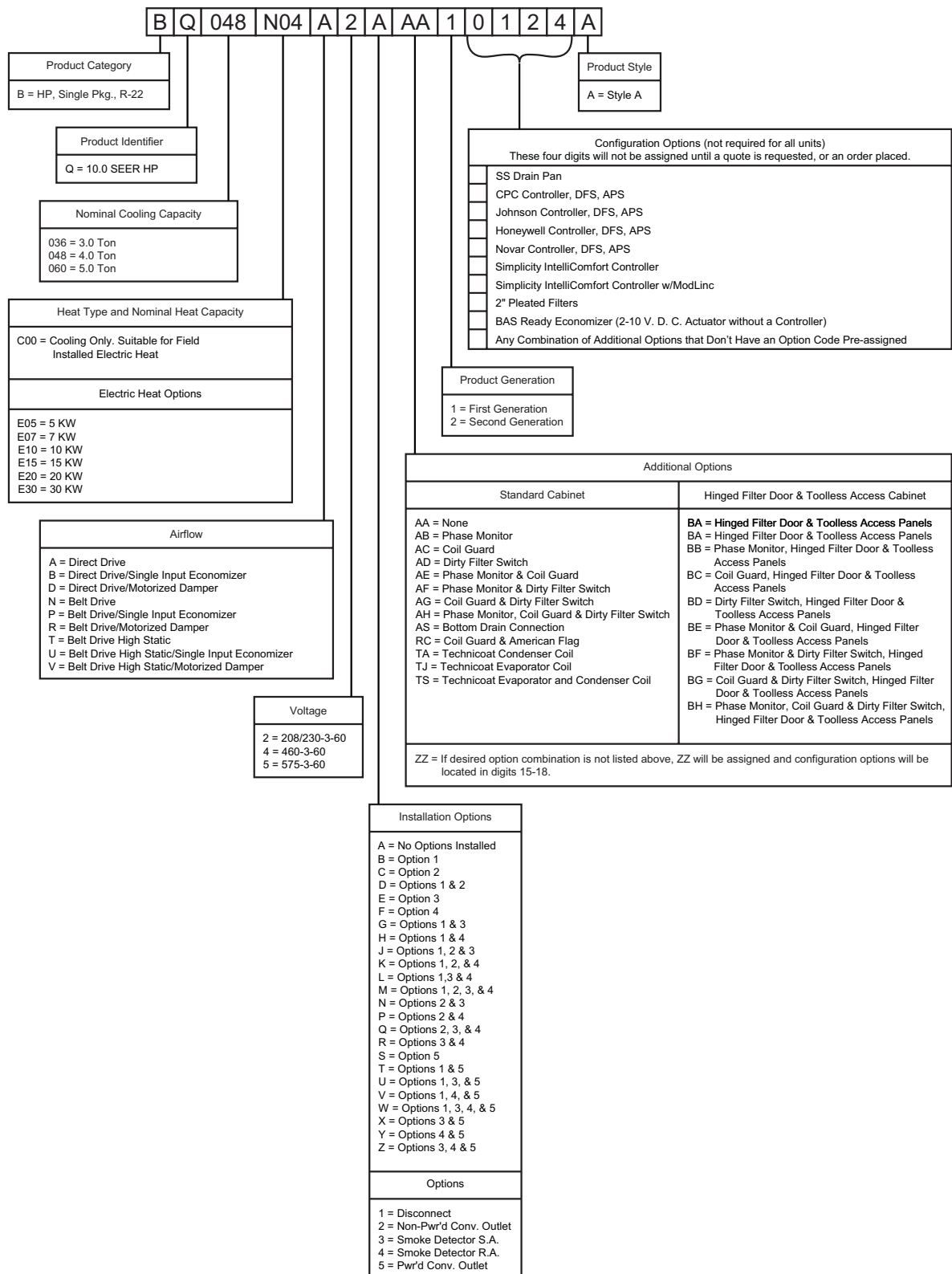

INSTALLATION

INSTALLATION SAFETY INFORMATION:

Read these instructions before continuing this appliance installation. This is an outdoor combination heating and cooling unit. The installer must assure that these instructions are made available to the consumer and with instructions to retain them for future reference.

1. Install this unit only in a location and position as specified on page 6 of these instructions.
2. This equipment is not to be used for temporary heating of buildings or structures under construction.

LIMITATIONS

These units must be installed in accordance with the following national and local safety codes:

In U.S.A.:

- National Electrical Code ANSI/NFPA No. 70.

In Canada:

- Current Canadian Electrical Code C22.1.
- Local plumbing and waste water codes.
- Other applicable local codes.

Refer to the Unit Application Data Table 1 and the Electrical Data table for the unit.

If components are to be added to a unit to meet local codes, they are to be installed at the dealer's and/or the customer's expense.

Size of unit for proposed installation should be based on heat loss/heat gain calculation made according to the methods of the Air Conditioning Contractors of America (ACCA).

This unit is not to be used for temporary heating of buildings or structures under construction.

TABLE 1: UNIT APPLICATION DATA (BQ)

UNIT MODEL NUMBER		036	048	060
Voltage Variation, Min. / Max. ¹	208/230	187 / 253		
	460	414 / 506		
	575	518 / 630		
Supply Air CFM, Nom.		1200	1600	2000
Wet Bulb Temperature (°F) of Air on Evaporator Coil, Min. / Max		57 / 72		
Dry Bulb Temperature (°F) of Air on Condenser Coil, Min. / Max.		0 / 120		

1. Utilization range "A" in accordance with ARI Standard 110.

LOCATION

Use the following guidelines to select a suitable location for these units.

1. Unit is designed for outdoor installation only.
2. Condenser coils must have an unlimited supply of air.
3. Where a choice of location is possible, position the unit on either north or east side of building.
4. For ground level installation, use a level concrete slab with a minimum thickness of 4 inches. The length and width should be at least 6 inches

greater than the unit base rails. Do not tie slab to the building foundation.

5. Roof structures must be able to support the weight of the unit and its options and/or accessories. Unit must be installed on a solid level roof curb or appropriate angle iron frame.
6. Maintain level tolerance to 1/2 inch maximum across the entire length or width of the unit.

If a unit is to be installed on a roof curb or special frame other than a YORK roof curb, gasketing must be applied to all surfaces that come in contact with the unit underside.

RIGGING AND HANDLING

Exercise care when moving the unit. Do not remove any packaging until the unit is near the place of installation. Rig the unit by attaching chain or cable slings to the lifting holes provided in the base rails. Spreader bars, whose length exceeds the largest dimension across the unit, **MUST BE USED**.

Units may also be moved or lifted with a forklift. Slotted openings in the base rails are provided for this purpose. Fork lengths must be a minimum of 42 inches.

Remove the nesting brackets from the four corners on the top of the unit. All screws that are removed when removing the brackets must be replaced on the unit.

Refer to Table 8 for unit weights and to the Figure 6 for approximate center of gravity.

CAUTION

Before lifting a unit, make sure that all panels are in place and that its weight is distributed equally on all cables so it will lift evenly.

CLEARANCES

All units require certain clearances for proper operation and service. Installer must make provisions for adequate ventilation air. Refer to Dimensions and Clearances shown in Figures 7 through 10 and Table 18 for the clearances required for combustible construction, servicing, and proper unit operation.

WARNING

Do not permit overhanging structures or shrubs to obstruct outdoor air discharge outlet, combustion air inlet or vent outlets.

DUCTWORK

Ductwork should be designed and sized according to the methods in Manual Q of the Air Conditioning Contractors of America (ACCA).

A closed return duct system shall be used. This shall not preclude use of economizers or outdoor fresh air intake. The supply and return air duct connections at the unit should be made with flexible joints to minimize noise.

The supply and return air duct systems should be designed for the CFM and static requirements of the job. They should **NOT** be sized to match the dimensions of the duct connections on the unit.

CAUTION

When fastening ductwork to side duct flanges on unit, insert screws through duct flanges only. **DO NOT** insert screws through casing. Outdoor ductwork must be insulated and waterproofed.

Refer to Figures 7 and 10 for information concerning side and bottom supply and return air duct openings.

CONDENSATE DRAIN

Plumbing must conform to local codes. Use a sealing compound on male pipe threads. Install a condensate drain line from the 3/4" NPT female connection on the unit to an open drain.

NOTE: The condensate drain operates in a negative pressure in the cabinet. The condensate drain line **MUST** be trapped to provide proper drainage. See Figure 1.

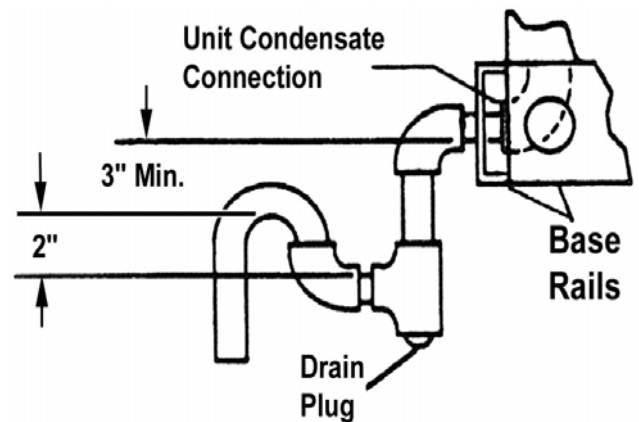

FIGURE 1 - RECOMMENDED DRAIN PIPING

COMPRESSORS

Units are shipped with compressor mountings factory-adjusted and ready for operation.

Units with scroll compressors have a shipping bracket which must be removed after the unit is set in place. See Figure 2.

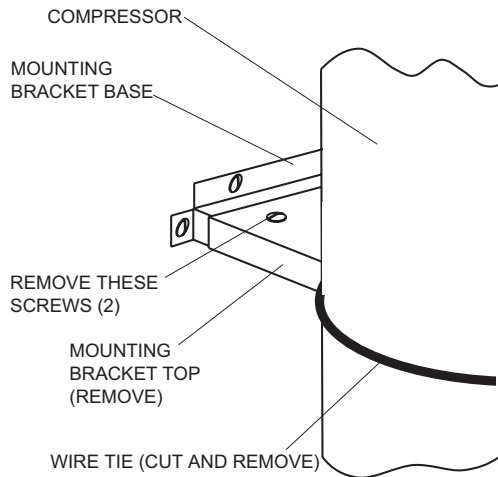

FIGURE 2 - COMPRESSOR RESTRAINING BRACKET

CAUTION

Do not loosen compressor mounting bolts.

FILTERS

One-inch or two-inch filters can be supplied with each unit. Filters must always be installed ahead of the evaporator coil and must be kept clean or replaced with same size and type. Dirty filters will reduce the capacity of the unit and will result in frosted coils or safety shut-down. Minimum filter area and required sizes are shown in Physical Data Table 7.

SERVICE ACCESS

The following removable panels provide access to all serviceable components:

- Compressor compartment
- Electric Heat compartment
- Blower compartment
- Main control box
- Filter compartment

Refer to the Dimensions and Clearances shown in Figures 7 and 11 for location of these access panels.

CAUTION

Make sure that all screws and panel latches are replaced and properly positioned on the unit to maintain an airtight seal.

TYPICAL POWER WIRING

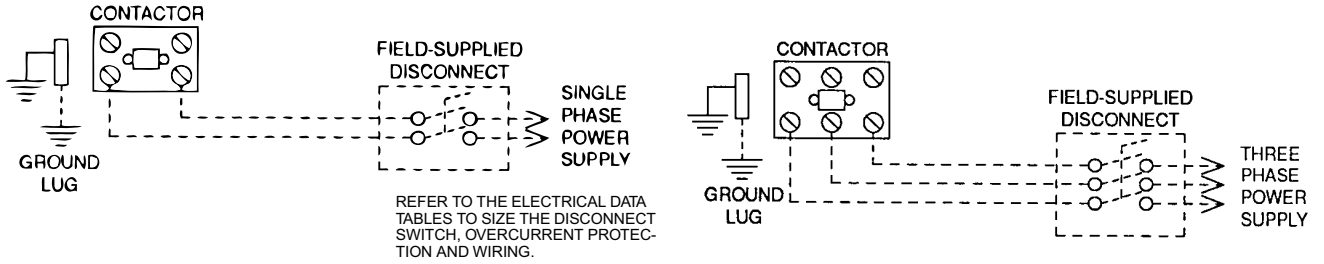

TYPICAL CONTROL WIRING COOLING / HEATING (24 VOLT THERMOSTAT)

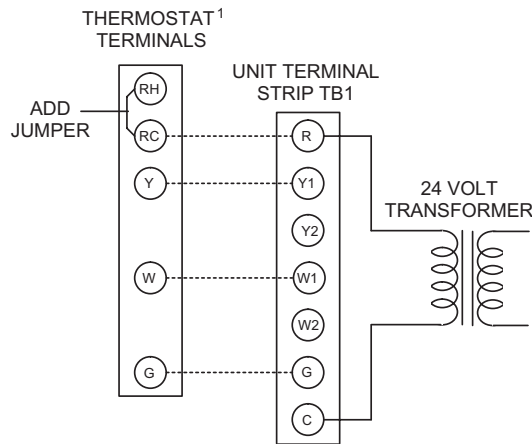

¹24 VOLT THERMOSTAT 2ET07701024. TO CONTROL THE ECONOMIZER ON THE SECOND STAGE COOLING OR TO HAVE AN ELECTRIC HEAT ACCESSORY WITH TWO STAGES OF HEAT, USE THERMOSTAT 2TH0471024.

COOLING / HEATING (ELECTRONIC THERMOSTAT) MULTI STAGE

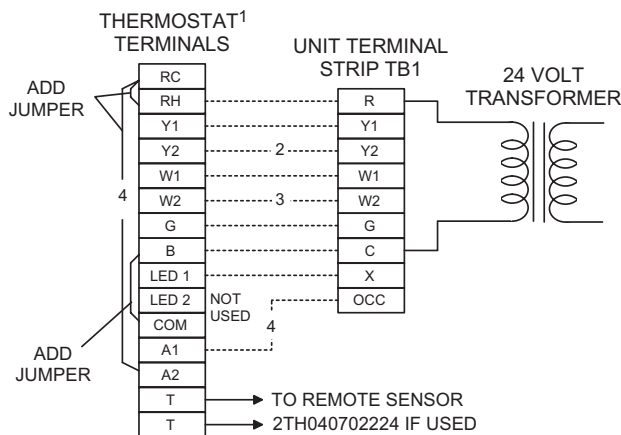

¹ ELECTRONIC PROGRAMMABLE THERMOSTAT 2ET04700224 (INCLUDES SUBBASE).
² SECOND STAGE COOLING IS NOT REQUIRED ON UNITS LESS ECONOMIZER.
³ SECOND STAGE HEATING IS ONLY REQUIRED ON UNITS WITH A TWO STAGE ELECTRIC HEATER OR 2 STAGE GAS HEAT.
⁴ REMOVE JUMPER J2 FROM TERMINALS 4 AND 9 ON JUMPER PLUG CONNECTOR P6 ON UNITS WITH ECONOMIZER. TERMINALS A1 AND A2 PROVIDE A RELAY OUTPUT TO CLOSE THE OUTDOOR ECONOMIZER DAMPERS WHEN THE THERMOSTAT SWITCHES TO THE SET-BACK POSITION.

COOLING / HEATING (ELECTRONIC THERMOSTAT) SINGLE STAGE

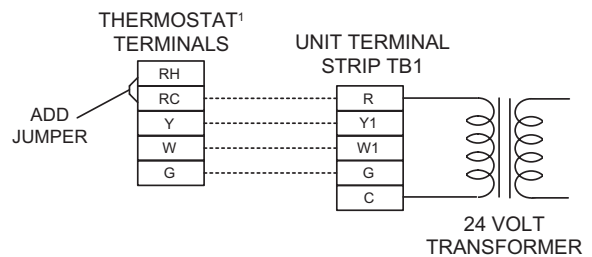

¹ELECTRONIC PROGRAMMABLE THERMOSTAT 2ET07701024 (INCLUDES SUBBASE). TO CONTROL THE ECONOMIZER ON SECOND STAGE COOLING, USE THERMOSTAT 2TH04700224.

FIGURE 3 - TYPICAL FIELD POWER & CONTROL WIRING

THERMOSTAT

The room thermostat should be located on an inside wall approximately 56 inches above the floor where it will not be subject to drafts, sun exposure or heat from electrical fixtures or appliances. Follow the manufacturer's instructions enclosed with the thermostat for general installation procedure. A minimum of seven color-coded insulated wires (#18 AWG) should be used to connect the thermostat to the unit.

POWER AND CONTROL WIRING

Field wiring to the unit must conform to provisions of the National Electrical Code, ANSI / NFPA No. 70 (in U.S.A.), current Canadian Electrical Code C22.1 (in Canada) and/or local ordinances. The unit must be electrically grounded in accordance with NEC and CEC (as specified above) and/or local codes. Voltage tolerances, which must be maintained at the compressor terminals, during starting and running conditions, are indicated on the unit Rating Plate and the Unit Application Data table.

The internal wiring harness furnished with this unit is an integral part of a CSA design certified unit. Field alteration to comply with electrical codes should not be required.

A fused disconnect switch should be field provided for the unit. The switch must be separate from all other circuits. Wire entry at knockout openings require conduit fittings to comply with NEC (in U.S.A.), CEC (in Canada) and/or local codes. If any of the wire supplied with the unit must be replaced, replacement wire must be of the type shown on the wiring diagram and the same minimum gauge as the replaced wire.

Use copper conductors properly sized to carry the load. Each unit must be wired with a separate branch circuit fed directly from the meter panel and properly fused.

CAUTION

When connecting electrical power and control wiring to the unit, waterproof type connectors **MUST BE USED** so that water or moisture cannot be drawn into the unit during normal operation. The above waterproofing conditions will also apply when installing a field-supplied disconnect switch.

Refer to the Typical Field Wiring Figure 3 and to the appropriate unit wiring diagram for control circuit and power wiring information.

TABLE 2: CONTROL WIRE SIZES

Wire Size	Maximum Length ¹
18 AWG	150 Feet

1. From the unit to the thermostat and back to the unit.

OPTIONS/ACCESSORIES

ELECTRIC HEAT

The factory- or field-installed heaters are wired for single point power supply. Power supply need only be brought into the single point terminal block and thermostat wiring to the low voltage terminal strip located in the upper portion of the unit control box.

These CSA approved heaters are located within the central compartment of the unit with the heater elements extending into the supply air chamber. Refer to Figure 7 for access panel location.

Fuses are supplied, where required, by the factory. Some KW sizes require fuses and others do not. Refer to Table 3 for minimum CFM limitations and to Tables 9 through 14 for electrical data.

TABLE 3: ELECTRIC HEATER CFM LIMITATIONS

UNIT MODEL SIZE NOMINAL TONS	VOLTAGE	MINIMUM SUPPLY AIR CFM					
		HEATER SIZE NOMINAL KW					
		5	7	10	15	20	30
036 (3)	208/230-1-60	900	900	900	900	900	-
	208/230-3-60	900	900	900	900	900	-
	460-3-60	-	900	900	900	900	-
	600-3-60	-	-	900	900	900	-
048 (4)	208/230-1-60	1200	1200	1200	1200	1200	-
	208/230-3-60	1200	1200	1200	1200	1200	-
	460-3-60	-	1200	1200	1200	1200	-
	600-3-60	-	-	1200	1200	1200	-
060 (5)	208/230-1-60	1500	1500	1500	1500	1500	1500
	208/230-3-60	1500	1500	1500	1500	1500	1500
	460-3-60	-	1500	1500	1500	1500	1500
	600-3-60	-	-	1500	1500	1500	1500

ECONOMIZER/MOTORIZED DAMPER AND RAIN HOOD

The instruction for the optional economizer/motorized damper and rain hood can be found in form 035-07364-000. Use these instructions when field assembling an economizer rain hood onto a unit. The outdoor and return air dampers, the damper actuator, the damper linkage, the outdoor and return air divider baffles, and all the control sensors are factory mounted as part of the "Factory installed" economizer/motorized damper options.

POWER EXHAUST/BAROMETRIC RELIEF DAMPER AND RAIN HOOD

The instructions for the power exhaust/barometric relief damper and rain hood can be found in form 530.18-N1.10V.

All of the components, including the dampers, hardware, and mounting instructions are shipped in a single package external from the unit and must be field assembled and installed.

Power exhaust is only available as a field installed accessory.

ECONOMIZER AND POWER EXHAUST DAMPER SET POINT ADJUSTMENTS AND INFORMATION

Remove the economizer access panel from the unit. Loosen but do not remove the two panel latches. Locate the economizer control module, where the following adjustments will be made.

 **CAUTION**

Extreme care must be exercised in turning all setpoint, maximum, and minimum damper positioning adjustment screws to prevent twisting them off.

Check that the damper blades move smoothly without binding; carefully turn the Minimum Position Adjusting screw (found on the damper control module) fully clockwise and then set the thermostat indoor fan switch to the on position and then off, or energize and de-energize terminals "R" to "G".

MINIMUM POSITION ADJUSTMENT

With thermostat set to indoor fan on position, or terminals “R” to “G” energized, turn the Minimum Position Adjusting screw (located on the damper control module) counterclockwise until the desired minimum damper position has been attained.

ENTHALPY SET POINT ADJUSTMENT

The enthalpy setpoint may now be set by selecting the desired setpoint shown in the Enthalpy Setpoint Adjustment Figure 4. Adjust as follows:

- For a single enthalpy operation carefully turn the setpoint adjusting screw (found on the damper control module) to the “A”, “B”, “C” or “D” setting corresponding to the lettered curve of the Enthalpy Setpoint Adjustment Figure 4.
- For a dual enthalpy operation, carefully turn the setpoint adjusting screw fully clockwise past the “D” setting.

POWER EXHAUST DAMPER SETPOINT (WITH OR WITHOUT POWER EXHAUST)

- With no power exhaust option, adjust the Exhaust Air Adjustment Screw fully clockwise.

- With power exhaust option, each building pressurization requirement will be different. The point at which the power exhaust comes on is determined by the economizer damper position (Percent Open). The Exhaust Air Adjustment Screw should be set at the Percent Open of the economizer damper at which the power exhaust is needed. It can be set from 0 to 100% damper open.

INDOOR AIR QUALITY

Indoor air quality (indoor sensor input): Terminal AQ accepts a +2 to +10 Vdc signal with respect to the (AQ1) terminal. When the signal is below it's setpoint, the actuator is allowed to modulate normally in accordance with the enthalpy and mixed air sensor inputs. When the AQ signal exceeds it's setpoint setting and there is no call for free cooling, the actuator is proportionately modulated from the 2 to 10 Vdc signal, with 2 Vdc corresponding to full closed and 10 Vdc corresponding to full open. When there is no call for free cooling, the damper position is limited by the IAQ Max damper position setting. When the signal exceeds it's setpoint (Demand Control Ventilation Setpoint) setting and there is a call for free cooling, the actuator modulates from the minimum position to the full open position based on the highest call from either the mixed air sensor input or the AQ voltage input.

- Optional CO₂ Space Sensor Kit Part # 2AQ04700324
- Optional CO₂ Unit Sensor Kit Part # 2AQ04700424

Replace the economizer access panel.

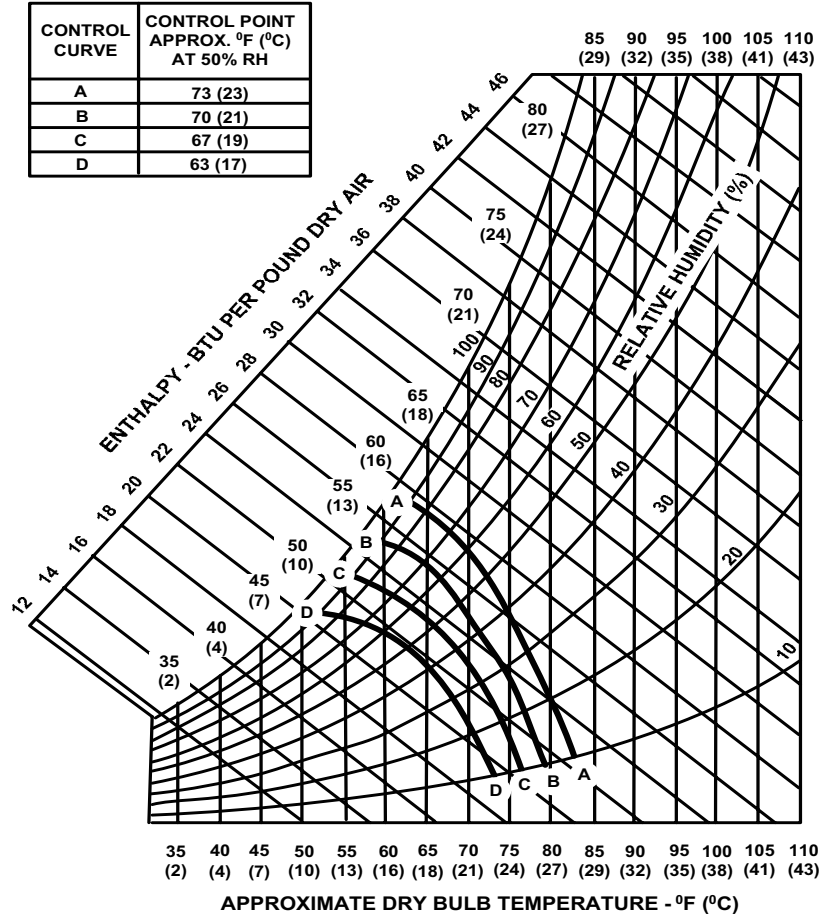

FIGURE 4 - ENTHALPY SETPOINT ADJUSTMENT

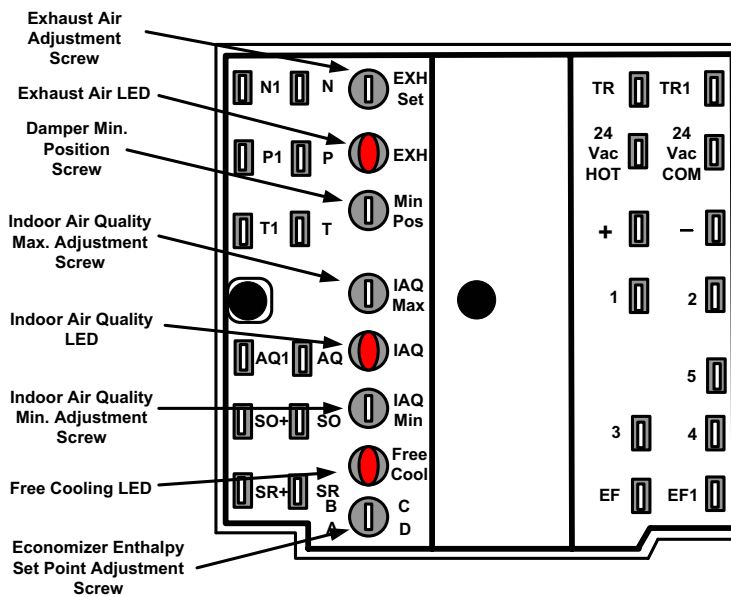

FIGURE 5 - HONEYWELL ECONOMIZER CONTROL W7212

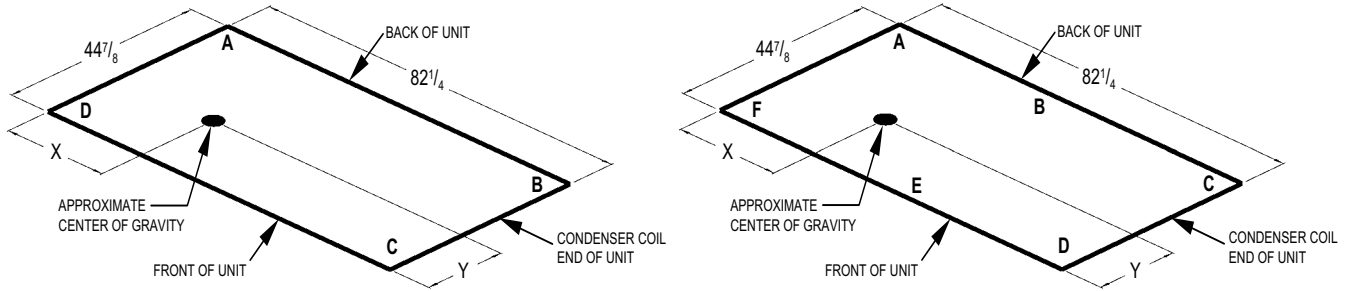

FIGURE 6 - FOUR AND SIX POINT LOADING

TABLE 4: CENTER OF GRAVITY (ALL MODELS)

DIMENSION	3 - 5 TON
X	40- ³ / ₄ "
Y	19- ³ / ₄ "

TABLE 5: BQ 4 POINT LOADS WEIGHT DISTRIBUTION

UNIT	TOTAL	A	B	C	D
BQ036	628	139	137	174	177
BQ048	668	148	146	185	189
BQ060	693	154	151	192	196

TABLE 6: BQ 6 POINT LOADS WEIGHT DISTRIBUTION

UNIT	TOTAL	A	B	C	D	E	F
BQ036	628	93	92	91	116	117	119
BQ048	668	99	98	97	123	125	126
BQ060	693	103	102	100	128	129	131

TABLE 7: PHYSICAL DATA

MODELS		BQ		
		036	048	060
EVAPORATOR BLOWER	Centrifugal Blower (Dia. x Wd. in.)	12 X 10	12 X 10	12 X 10
	Fan Motor HP (Direct Drive)	1/2	3/4	1
	Fan Motor HP (Belt Drive)	1 1/2	1 1/2	1 1/2
	Fan Motor HP (Belt Drive High Static)	1 1/2	1 1/2	2
EVAPORATOR COIL	Rows Deep	4	3	3
	Fins Per Inch	16	15	15
	Face Area (Sq. Ft.)	4.3	5.1	5.1
CONDENSER FANS	Propeller Dia. (in.)	22	22	24
	Fan Motor Hp	1/3	1/2	1/2
	Nom. CFM	4300	4200	4500
CONDENSER COILS	Rows Deep	1	1	1
	Fins Per Inch	20	20	20
	Face Area (Sq. Ft.)	17.1	17.1	17.1
COMPRESSOR (Qty. Per Unit)	Reciprocating Type	1	1	1
AIR FILTERS	Quantity Per Unit (15" X 20" X 1" or 2")	2	2	2
	Quantity Per Unit (14" X 25" X 1" or 2")	1	1	1
	Total Face Area (sq. ft.)	6.6	6.6	6.6
CHARGE	Refrigerant 22 (lbs./oz.)	7/12	9/2	8/4

TABLE 8: OPERATING WEIGHTS (LBS.)

MODEL SIZE		3 TON	4 TON	5 TON	
BASIC UNIT	BQ	628	668	693	
OPTIONS	Economizer	50			
	Motorized Damper	26			
	Electric Heater	5 - 7 kW	18		
		10 - 15 kW	23		
20 - 30 kW		28			
ACCY.	Roof Curb	92			
	Barometric Relief / Fixed Air Damper	10			
	Belt-Drive Blower	5			

TABLE 9: ELECTRICAL DATA - BQ036-060 DIRECT DRIVE W/O POWERED CONVENIENCE OUTLET

Size (Tons)	Volt	Compressors (each)			OD Fan Motors (each)	Supply Blower Motor	Pwr Conv Outlet	Electric Heat Option				MCA ¹ (Amps)	Max Fuse ² / Breaker ³ Size (Amps)
		RLA	LRA	MCC	FLA	FLA	FLA	Model	kW	Stages	Amps		
036 (3.0)	208-3-60	11.9	85.0	16.7	1.7	4.4	0.0	None	-	-	-	21.0	30
								E05	4.0	1	11.1	34.9	40
								E07	5.6	1	15.5	40.4	45
								E10	8.0	1	22.2	48.7	50
								E15	11.9	2	33.0	62.3	70
								E20	15.9	2	44.1	76.1	80
	230-3-60	11.9	85.0	16.7	1.7	4.4	0.0	None	-	-	-	21.0	30
								E05	5.3	1	13.3	36.9	45
								E07	7.5	1	18.8	43.5	50
								E10	10.6	1	26.6	52.8	60
								E15	15.9	2	39.9	68.8	70
								E20	21.2	2	53.2	84.7	90
460-3-60	5.9	42.0	8.2	1.0	2.2	0.0	None	-	-	-	10.6	15	
							E07	6.8	1	8.5	20.8	25	
							E10	10.1	1	12.7	25.8	30	
							E15	13.6	2	17.1	31.0	35	
							E20	19.5	2	24.5	39.9	40	
							None	-	-	-	8.6	15	
575-3-60	4.8	34.0	6.7	1.0	2.2	0.0	None	-	-	-	8.6	15	
							E10	10.6	1	10.6	21.3	25	
							E15	15.9	1	16.0	27.7	30	
							E20	21.2	2	21.3	34.1	35	
							None	-	-	-	8.6	15	
							E10	10.6	1	10.6	21.3	25	
048 (4.0)	208-3-60	14.7	130.0	23.0	2.3	5.0	0.0	None	-	-	-	25.7	35
								E05	4.0	1	11.1	39.6	50
								E07	5.6	1	15.5	45.1	50
								E10	8.0	1	22.2	53.4	60
								E15	11.9	2	33.0	67.0	70
								E20	15.9	2	44.1	80.8	90
	230-3-60	14.7	130.0	23.0	2.3	5.0	0.0	None	-	-	-	25.7	35
								E05	5.3	1	13.3	41.6	50
								E07	7.5	1	18.8	48.2	50
								E10	10.6	1	26.6	57.5	60
								E15	15.9	2	39.9	73.5	80
								E20	21.2	2	53.2	89.4	90
460-3-60	7.7	64.0	12.0	1.3	2.2	0.0	None	-	-	-	13.1	20	
							E07	6.8	1	8.5	23.3	25	
							E10	10.1	1	12.7	28.3	30	
							E15	13.6	2	17.1	33.6	35	
							E20	19.5	2	24.5	42.4	45	
							None	-	-	-	10.8	15	
575-3-60	6.4	52.0	10.0	1.3	2.2	0.0	None	-	-	-	10.8	15	
							E10	10.6	1	10.6	23.5	25	
							E15	15.9	1	16.0	29.9	30	
							E20	21.2	2	21.3	36.3	40	
							None	-	-	-	10.8	15	
							E10	10.6	1	10.6	23.5	25	
060 (5.0)	208-3-60	19.3	137.0	27.0	2.3	6.6	0.0	None	-	-	-	33.0	45
								E05	4.0	1	11.1	46.9	60
								E07	5.6	1	15.5	52.5	60
								E10	8.0	1	22.2	60.8	70
								E15	11.9	2	33.0	74.3	80
								E20	15.9	2	44.1	88.2	90
	E30	22.2	2	61.6	110.1	125							
	230-3-60	19.3	137.0	27.0	2.3	6.6	0.0	None	-	-	-	33.0	45
								E05	5.3	1	13.3	49.0	60
								E07	7.5	1	18.8	55.6	70
								E10	10.6	1	26.6	64.9	70
								E15	15.9	2	39.9	80.8	90
E20								21.2	2	53.2	96.8	100	
E30	29.6	2	74.3	122.0	125								
460-3-60	10.0	62.0	14.0	1.3	3.3	0.0	None	-	-	-	17.1	25	
							E07	6.8	1	8.5	27.3	35	
							E10	10.1	1	12.7	32.3	35	
							E15	13.6	2	17.1	37.5	40	
							E20	19.5	2	24.5	46.4	50	
							E30	28.8	2	36.1	60.4	70	
575-3-60	7.9	50.0	11.0	1.3	3.3	0.0	None	-	-	-	13.5	20	
							E10	10.6	1	10.6	26.2	30	
							E15	15.9	1	16.0	32.6	35	
							E20	21.2	2	21.3	39.0	40	
							None	-	-	-	13.5	20	
							E10	10.6	1	10.6	26.2	30	
E15	15.9	1	16.0	32.6	35								
E20	21.2	2	21.3	39.0	40								
E30	30.4	2	30.5	50.1	60								

1. Minimum Circuit Ampacity.
2. Dual Element, Time Delay Type.
3. HACR type per NEC.

TABLE 10: ELECTRICAL DATA - BQ036-060 BELT DRIVE W/O POWERED CONVENIENCE OUTLET

Size (Tons)	Volt	Compressors (each)			OD Fan Motors (each)	Supply Blower Motor	Pwr Conv Outlet	Electric Heat Option				MCA ¹ (Amps)	Max Fuse ² / Breaker ³ Size (Amps)
		RLA	LRA	MCC	FLA	FLA	FLA	Model	kW	Stages	Amps		
036 (3.0)	208-3-60	11.9	85.0	16.7	1.7	5.2	0.0	None	-	-	-	21.8	30
								E05	4.0	1	11.1	35.7	40
								E07	5.6	1	15.5	41.2	45
								E10	8.0	1	22.2	49.5	50
								E15	11.9	2	33.0	63.1	70
	230-3-60	11.9	85.0	16.7	1.7	5.2	0.0	None	-	-	-	21.8	30
								E05	5.3	1	13.3	37.7	45
								E07	7.5	1	18.8	44.3	50
								E10	10.6	1	26.6	53.6	60
								E15	15.9	2	39.9	69.6	70
	460-3-60	5.9	42.0	8.2	1.0	2.6	0.0	None	-	-	-	11.0	15
								E07	6.8	1	8.5	21.2	25
								E10	10.1	1	12.7	26.2	30
								E15	13.6	2	17.1	31.4	35
								E20	19.5	2	24.5	40.3	45
	575-3-60	4.8	34.0	6.7	1.0	2.0	0.0	None	-	-	-	8.8	15
								E10	10.6	1	10.6	21.5	25
								E15	15.9	1	16.0	27.9	30
								E20	21.2	2	21.3	34.3	35
								None	-	-	-	-	-
048 (4.0)	208-3-60	14.7	130.0	23.0	2.3	5.2	0.0	None	-	-	-	25.9	35
								E05	4.0	1	11.1	39.8	50
								E07	5.6	1	15.5	45.3	50
								E10	8.0	1	22.2	53.6	60
								E15	11.9	2	33.0	67.2	70
	230-3-60	14.7	130.0	23.0	2.3	5.2	0.0	None	-	-	-	25.9	35
								E05	5.3	1	13.3	41.8	50
								E07	7.5	1	18.8	48.4	50
								E10	10.6	1	26.6	57.7	60
								E15	15.9	2	39.9	73.7	80
	460-3-60	7.7	64.0	12.0	1.3	2.6	0.0	None	-	-	-	13.5	20
								E07	6.8	1	8.5	23.7	25
								E10	10.1	1	12.7	28.7	30
								E15	13.6	2	17.1	34.0	35
								E20	19.5	2	24.5	42.8	45
	575-3-60	6.4	52.0	10.0	1.3	2.0	0.0	None	-	-	-	11.0	15
								E10	10.6	1	10.6	23.8	25
								E15	15.9	1	16.0	30.2	35
								E20	21.2	2	21.3	36.5	40
								None	-	-	-	-	-
060 (5.0)	208-3-60	19.3	137.0	27.0	2.3	5.2	0.0	None	-	-	-	31.6	40
								E05	4.0	1	11.1	45.5	60
								E07	5.6	1	15.5	51.1	60
								E10	8.0	1	22.2	59.4	70
								E15	11.9	2	33.0	72.9	80
	230-3-60	19.3	137.0	27.0	2.3	5.2	0.0	None	-	-	-	31.6	40
								E05	5.3	1	13.3	47.6	60
								E07	7.5	1	18.8	54.2	60
								E10	10.6	1	26.6	63.5	70
								E15	15.9	2	39.9	79.4	80
	460-3-60	10.0	62.0	14.0	1.3	2.6	0.0	None	-	-	-	16.4	25
								E07	6.8	1	8.5	26.6	30
								E10	10.1	1	12.7	31.6	35
								E15	13.6	2	17.1	36.8	40
								E20	19.5	2	24.5	45.7	50
	575-3-60	7.9	50.0	11.0	1.3	2.0	0.0	None	-	-	-	12.9	20
								E10	10.6	1	10.6	25.6	30
								E15	15.9	1	16.0	32.0	35
								E20	21.2	2	21.3	38.4	40
								E30	30.4	2	30.5	49.4	50

1. Minimum Circuit Ampacity.
2. Dual Element, Time Delay Type.
3. HACR type per NEC.

TABLE 11: ELECTRICAL DATA - BQ036-060 BELT DRIVE HIGH STATIC W/O POWERED CONVENIENCE OUTLET

Size (Tons)	Volt	Compressors (each)			OD Fan Motors (each)	Supply Blower Motor	Pwr Conv Outlet	Electric Heat Option				MCA ¹ (Amps)	Max Fuse ² / Breaker ³ Size (Amps)
		RLA	LRA	MCC	FLA	FLA	FLA	Model	kW	Stages	Amps		
036 (3.0)	208-3-60	11.9	85.0	16.7	1.7	5.2	0.0	None	-	-	-	21.8	30
								E05	4.0	1	11.1	35.7	40
								E07	5.6	1	15.5	41.2	45
								E10	8.0	1	22.2	49.5	50
								E15	11.9	2	33.0	63.1	70
	230-3-60	11.9	85.0	16.7	1.7	5.2	0.0	E20	15.9	2	44.1	76.9	80
								None	-	-	-	21.8	30
								E05	5.3	1	13.3	37.7	45
								E07	7.5	1	18.8	44.3	50
								E10	10.6	1	26.6	53.6	60
	460-3-60	5.9	42.0	8.2	1.0	2.6	0.0	E15	15.9	2	39.9	69.6	70
								E20	21.2	2	53.2	85.5	90
								None	-	-	-	11.0	15
								E07	6.8	1	8.5	21.2	25
								E10	10.1	1	12.7	26.2	30
	575-3-60	4.8	34.0	6.7	1.0	2.0	0.0	E15	13.6	2	17.1	31.4	35
								E20	19.5	2	24.5	40.3	45
								None	-	-	-	8.8	15
								E10	10.6	1	10.6	21.5	25
								E15	15.9	1	16.0	27.9	30
048 (4.0)	208-3-60	14.7	130.0	23.0	2.3	5.2	0.0	E20	21.2	2	21.3	34.3	35
								None	-	-	-	25.9	35
								E05	4.0	1	11.1	39.8	50
								E07	5.6	1	15.5	45.3	50
								E10	8.0	1	22.2	53.6	60
	230-3-60	14.7	130.0	23.0	2.3	5.2	0.0	E15	11.9	2	33.0	67.2	70
								E20	15.9	2	44.1	81.0	90
								None	-	-	-	25.9	35
								E05	5.3	1	13.3	41.8	50
								E07	7.5	1	18.8	48.4	50
	460-3-60	7.7	64.0	12.0	1.3	2.6	0.0	E10	10.6	1	26.6	57.7	60
								E15	15.9	2	39.9	73.7	80
								E20	21.2	2	53.2	89.6	90
								None	-	-	-	13.5	20
								E07	6.8	1	8.5	23.7	25
	575-3-60	6.4	52.0	10.0	1.3	2.0	0.0	E10	10.1	1	12.7	28.7	30
								E15	13.6	2	17.1	34.0	35
								E20	19.5	2	24.5	42.8	45
								None	-	-	-	11.0	15
								E10	10.6	1	10.6	23.8	25
060 (5.0)	208-3-60	19.3	137.0	27.0	2.3	8.2	0.0	E15	15.9	1	16.0	30.2	35
								E20	21.2	2	21.3	36.5	40
								None	-	-	-	34.6	45
								E05	4.0	1	11.1	48.5	60
								E07	5.6	1	15.5	54.1	60
	230-3-60	19.3	137.0	27.0	2.3	8.2	0.0	E10	8.0	1	22.2	62.4	70
								E15	11.9	2	33.0	75.9	80
								E20	15.9	2	44.1	89.8	90
								E30	22.2	2	61.6	111.7	125
								None	-	-	-	34.6	45
	460-3-60	10.0	62.0	14.0	1.3	4.1	0.0	E05	5.3	1	13.3	50.6	60
								E07	7.5	1	18.8	57.2	70
								E10	10.6	1	26.6	66.5	70
								E15	15.9	2	39.9	82.4	90
								E20	21.2	2	53.2	98.4	100
	575-3-60	7.9	50.0	11.0	1.3	3.6	0.0	E30	29.6	2	74.3	123.6	125
								None	-	-	-	17.9	25
								E07	6.8	1	8.5	28.1	35
								E10	10.1	1	12.7	33.1	40
								E15	13.6	2	17.1	38.3	40
							E20	19.5	2	24.5	47.2	50	
							E30	28.8	2	36.1	61.2	70	
							None	-	-	-	14.5	20	
							E10	10.6	1	10.6	27.2	30	
							E15	15.9	1	16.0	33.6	35	
							E20	21.2	2	21.3	40.0	40	
							E30	30.4	2	30.5	51.0	60	

1. Minimum Circuit Ampacity.
2. Dual Element, Time Delay Type.
3. HACR type per NEC.

TABLE 12: ELECTRICAL DATA - BQ036-060 DIRECT DRIVE W/POWERED CONVENIENCE OUTLET

Size (Tons)	Volt	Compressors (each)			OD Fan Motors (each)	Supply Blower Motor	Pwr Conv Outlet	Electric Heat Option				MCA ¹ (Amps)	Max Fuse ² / Breaker ³ Size (Amps)
		RLA	LRA	MCC	FLA	FLA	FLA	Model	kW	Stages	Amps		
036 (3.0)	208-3-60	11.9	85.0	16.7	1.7	4.4	10.0	None	-	-	-	31.0	40
								E05	4.0	1	11.1	44.9	50
								E07	5.6	1	15.5	50.4	60
								E10	8.0	1	22.2	58.7	60
								E15	11.9	2	33.0	72.3	80
	230-3-60	11.9	85.0	16.7	1.7	4.4	10.0	None	-	-	-	31.0	40
								E05	5.3	1	13.3	46.9	50
								E07	7.5	1	18.8	53.5	60
								E10	10.6	1	26.6	62.8	70
								E15	15.9	2	39.9	78.8	80
	460-3-60	5.9	42.0	8.2	1.0	2.2	5.0	None	-	-	-	15.6	20
								E07	6.8	1	8.5	25.8	30
								E10	10.1	1	12.7	30.8	35
								E15	13.6	2	17.1	36.0	40
								E20	19.5	2	24.5	44.9	45
	575-3-60	4.8	34.0	6.7	1.0	2.2	4.0	None	-	-	-	12.6	15
								E10	10.6	1	10.6	25.3	30
								E15	15.9	1	16.0	31.7	35
								E20	21.2	2	21.3	38.1	40
								None	-	-	-	-	-
048 (4.0)	208-3-60	14.7	130.0	23.0	2.3	5.0	10.0	None	-	-	-	35.7	45
								E05	4.0	1	11.1	49.6	60
								E07	5.6	1	15.5	55.1	60
								E10	8.0	1	22.2	63.4	70
								E15	11.9	2	33.0	77.0	80
	230-3-60	14.7	130.0	23.0	2.3	5.0	10.0	None	-	-	-	35.7	45
								E05	5.3	1	13.3	51.6	60
								E07	7.5	1	18.8	58.2	60
								E10	10.6	1	26.6	67.5	70
								E15	15.9	2	39.9	83.5	90
	460-3-60	7.7	64.0	12.0	1.3	2.2	5.0	None	-	-	-	18.1	25
								E07	6.8	1	8.5	28.3	30
								E10	10.1	1	12.7	33.3	35
								E15	13.6	2	17.1	38.6	40
								E20	19.5	2	24.5	47.4	50
	575-3-60	6.4	52.0	10.0	1.3	2.2	4.0	None	-	-	-	14.8	20
								E10	10.6	1	10.6	27.5	30
								E15	15.9	1	16.0	33.9	35
								E20	21.2	2	21.3	40.3	45
								None	-	-	-	-	-
060 (5.0)	208-3-60	19.3	137.0	27.0	2.3	6.6	10.0	None	-	-	-	43.0	60
								E05	4.0	1	11.1	56.9	70
								E07	5.6	1	15.5	62.5	70
								E10	8.0	1	22.2	70.8	80
								E15	11.9	2	33.0	84.3	90
								E20	15.9	2	44.1	98.2	100
	230-3-60	19.3	137.0	27.0	2.3	6.6	10.0	None	-	-	-	43.0	60
								E05	5.3	1	13.3	59.0	70
								E07	7.5	1	18.8	65.6	80
								E10	10.6	1	26.6	74.9	80
								E15	15.9	2	39.9	90.8	100
								E20	21.2	2	53.2	106.8	110
	460-3-60	10.0	62.0	14.0	1.3	3.3	5.0	None	-	-	-	22.1	30
								E07	6.8	1	8.5	32.3	40
								E10	10.1	1	12.7	37.3	40
								E15	13.6	2	17.1	42.5	45
								E20	19.5	2	24.5	51.4	60
								E30	28.8	2	36.1	65.4	70
	575-3-60	7.9	50.0	11.0	1.3	3.3	4.0	None	-	-	-	17.5	25
								E10	10.6	1	10.6	30.2	35
E15								15.9	1	16.0	36.6	40	
E20								21.2	2	21.3	43.0	45	
E30								30.4	2	30.5	54.1	60	

1. Minimum Circuit Ampacity.
2. Dual Element, Time Delay Type.
3. HACR type per NEC.

TABLE 13: ELECTRICAL DATA - BQ036-060 BELT DRIVE W/POWERED CONVENIENCE OUTLET

Size (Tons)	Volt	Compressors (each)			OD Fan Motors (each)	Supply Blower Motor	Pwr Conv Outlet	Electric Heat Option				MCA ¹ (Amps)	Max Fuse ² / Breaker ³ Size (Amps)
		RLA	LRA	MCC	FLA	FLA	FLA	Model	kW	Stages	Amps		
036 (3.0)	208-3-60	11.9	85.0	16.7	1.7	5.2	10.0	None	-	-	-	31.8	40
								E05	4.0	1	11.1	45.7	50
								E07	5.6	1	15.5	51.2	60
								E10	8.0	1	22.2	59.5	60
								E15	11.9	2	33.0	73.1	80
	E20	15.9	2	44.1	86.9	90							
	230-3-60	11.9	85.0	16.7	1.7	5.2	10.0	None	-	-	-	31.8	40
								E05	5.3	1	13.3	47.7	50
								E07	7.5	1	18.8	54.3	60
								E10	10.6	1	26.6	63.6	70
								E15	15.9	2	39.9	79.6	80
	E20	21.2	2	53.2	95.5	100							
	460-3-60	5.9	42.0	8.2	1.0	2.6	5.0	None	-	-	-	16.0	20
								E07	6.8	1	8.5	26.2	30
								E10	10.1	1	12.7	31.2	35
								E15	13.6	2	17.1	36.4	40
								E20	19.5	2	24.5	45.3	50
	575-3-60	4.8	34.0	6.7	1.0	2.0	4.0	None	-	-	-	12.8	15
								E10	10.6	1	10.6	25.5	30
								E15	15.9	1	16.0	31.9	35
E20								21.2	2	21.3	38.3	40	
None								-	-	-	-	-	
048 (4.0)	208-3-60	14.7	130.0	23.0	2.3	5.2	10.0	None	-	-	-	35.9	50
								E05	4.0	1	11.1	49.8	60
								E07	5.6	1	15.5	55.3	60
								E10	8.0	1	22.2	63.6	70
								E15	11.9	2	33.0	77.2	80
	E20	15.9	2	44.1	91.0	100							
	230-3-60	14.7	130.0	23.0	2.3	5.2	10.0	None	-	-	-	35.9	50
								E05	5.3	1	13.3	51.8	60
								E07	7.5	1	18.8	58.4	60
								E10	10.6	1	26.6	67.7	70
								E15	15.9	2	39.9	83.7	90
	E20	21.2	2	53.2	99.6	100							
	460-3-60	7.7	64.0	12.0	1.3	2.6	5.0	None	-	-	-	18.5	25
								E07	6.8	1	8.5	28.7	30
								E10	10.1	1	12.7	33.7	35
								E15	13.6	2	17.1	39.0	40
								E20	19.5	2	24.5	47.8	50
	575-3-60	6.4	52.0	10.0	1.3	2.0	4.0	None	-	-	-	15.0	20
								E10	10.6	1	10.6	27.8	30
								E15	15.9	1	16.0	34.2	35
E20								21.2	2	21.3	40.5	45	
None								-	-	-	-	-	
060 (5.0)	208-3-60	19.3	137.0	27.0	2.3	5.2	10.0	None	-	-	-	41.6	60
								E05	4.0	1	11.1	55.5	70
								E07	5.6	1	15.5	61.1	70
								E10	8.0	1	22.2	69.4	80
								E15	11.9	2	33.0	82.9	90
	E20	15.9	2	44.1	96.8	100							
	E30	22.2	2	61.6	118.7	125							
	230-3-60	19.3	137.0	27.0	2.3	5.2	10.0	None	-	-	-	41.6	60
								E05	5.3	1	13.3	57.6	70
								E07	7.5	1	18.8	64.2	70
								E10	10.6	1	26.6	73.5	80
								E15	15.9	2	39.9	89.4	90
	E20	21.2	2	53.2	105.4	110							
	E30	29.6	2	74.3	130.6	150							
	460-3-60	10.0	62.0	14.0	1.3	2.6	5.0	None	-	-	-	21.4	30
								E07	6.8	1	8.5	31.6	35
								E10	10.1	1	12.7	36.6	40
								E15	13.6	2	17.1	41.8	45
								E20	19.5	2	24.5	50.7	60
	E30	28.8	2	36.1	64.7	70							
575-3-60	7.9	50.0	11.0	1.3	2.0	4.0	None	-	-	-	16.9	20	
							E10	10.6	1	10.6	29.6	30	
							E15	15.9	1	16.0	36.0	40	
							E20	21.2	2	21.3	42.4	45	
							E30	30.4	2	30.5	53.4	60	

1. Minimum Circuit Ampacity.
2. Dual Element, Time Delay Type.
3. HACR type per NEC.

TABLE 14: ELECTRICAL DATA - BQ036-060 BELT DRIVE HIGH STATIC W/POWERED CONVENIENCE OUTLET

Size (Tons)	Volt	Compressors (each)			OD Fan Motors (each)	Supply Blower Motor	Pwr Conv Outlet	Electric Heat Option				MCA ¹ (Amps)	Max Fuse ² / Breaker ³ Size (Amps)
		RLA	LRA	MCC	FLA	FLA	FLA	Model	kW	Stages	Amps		
036 (3.0)	208-3-60	11.9	85.0	16.7	1.7	5.2	10.0	None	-	-	-	31.8	40
								E05	4.0	1	11.1	45.7	50
								E07	5.6	1	15.5	51.2	60
								E10	8.0	1	22.2	59.5	60
								E15	11.9	2	33.0	73.1	80
								E20	15.9	2	44.1	86.9	90
	230-3-60	11.9	85.0	16.7	1.7	5.2	10.0	None	-	-	-	31.8	40
								E05	5.3	1	13.3	47.7	50
								E07	7.5	1	18.8	54.3	60
								E10	10.6	1	26.6	63.6	70
								E15	15.9	2	39.9	79.6	80
								E20	21.2	2	53.2	95.5	100
	460-3-60	5.9	42.0	8.2	1.0	2.6	5.0	None	-	-	-	16.0	20
								E07	6.8	1	8.5	26.2	30
								E10	10.1	1	12.7	31.2	35
								E15	13.6	2	17.1	36.4	40
								E20	19.5	2	24.5	45.3	50
	575-3-60	4.8	34.0	6.7	1.0	2.0	4.0	None	-	-	-	12.8	15
								E10	10.6	1	10.6	25.5	30
								E15	15.9	1	16.0	31.9	35
E20								21.2	2	21.3	38.3	40	
048 (4.0)	208-3-60	14.7	130.0	23.0	2.3	5.2	10.0	None	-	-	-	35.9	50
								E05	4.0	1	11.1	49.8	60
								E07	5.6	1	15.5	55.3	60
								E10	8.0	1	22.2	63.6	70
								E15	11.9	2	33.0	77.2	80
								E20	15.9	2	44.1	91.0	100
	230-3-60	14.7	130.0	23.0	2.3	5.2	10.0	None	-	-	-	35.9	50
								E05	5.3	1	13.3	51.8	60
								E07	7.5	1	18.8	58.4	60
								E10	10.6	1	26.6	67.7	70
								E15	15.9	2	39.9	83.7	90
								E20	21.2	2	53.2	99.6	100
	460-3-60	7.7	64.0	12.0	1.3	2.6	5.0	None	-	-	-	18.5	25
								E07	6.8	1	8.5	28.7	30
								E10	10.1	1	12.7	33.7	35
								E15	13.6	2	17.1	39.0	40
								E20	19.5	2	24.5	47.8	50
	575-3-60	6.4	52.0	10.0	1.3	2.0	4.0	None	-	-	-	15.0	20
								E10	10.6	1	10.6	27.8	30
								E15	15.9	1	16.0	34.2	35
E20								21.2	2	21.3	40.5	45	
060 (5.0)	208-3-60	19.3	137.0	27.0	2.3	8.2	10.0	None	-	-	-	44.6	60
								E05	4.0	1	11.1	58.5	70
								E07	5.6	1	15.5	64.1	70
								E10	8.0	1	22.2	72.4	80
								E15	11.9	2	33.0	85.9	90
								E20	15.9	2	44.1	99.8	100
	230-3-60	19.3	137.0	27.0	2.3	8.2	10.0	None	-	-	-	44.6	60
								E05	5.3	1	13.3	60.6	70
								E07	7.5	1	18.8	67.2	80
								E10	10.6	1	26.6	76.5	80
								E15	15.9	2	39.9	92.4	100
								E20	21.2	2	53.2	108.4	110
	460-3-60	10.0	62.0	14.0	1.3	4.1	5.0	None	-	-	-	22.9	30
								E07	6.8	1	8.5	33.1	40
								E10	10.1	1	12.7	38.1	45
								E15	13.6	2	17.1	43.3	45
								E20	19.5	2	24.5	52.2	60
								E30	28.8	2	36.1	66.2	70
	575-3-60	7.9	50.0	11.0	1.3	3.6	4.0	None	-	-	-	18.5	25
								E10	10.6	1	10.6	31.2	35
E15								15.9	1	16.0	37.6	40	
E20								21.2	2	21.3	44.0	45	
E30								30.4	2	30.5	55.0	60	

1. Minimum Circuit Ampacity.
2. Dual Element, Time Delay Type.
3. HACR type per NEC.

TABLE 15: ELECTRIC HEAT CORRECTION FACTORS

NOMINAL VOLTAGE	VOLTAGE	KW CAP. MULTIPLIER
208	208	0.75
240	230	0.92
480	460	0.92
600	575	0.92

TABLE 16: VOLTAGE LIMITATIONS¹

POWER SUPPLY	VOLTAGE	
	MIN.	MAX.
208/230-3-60	187	253
460-3-60	414	506
575-3-60	518	630

1. Utilization Range "A" in accordance with ARI Standard 110.

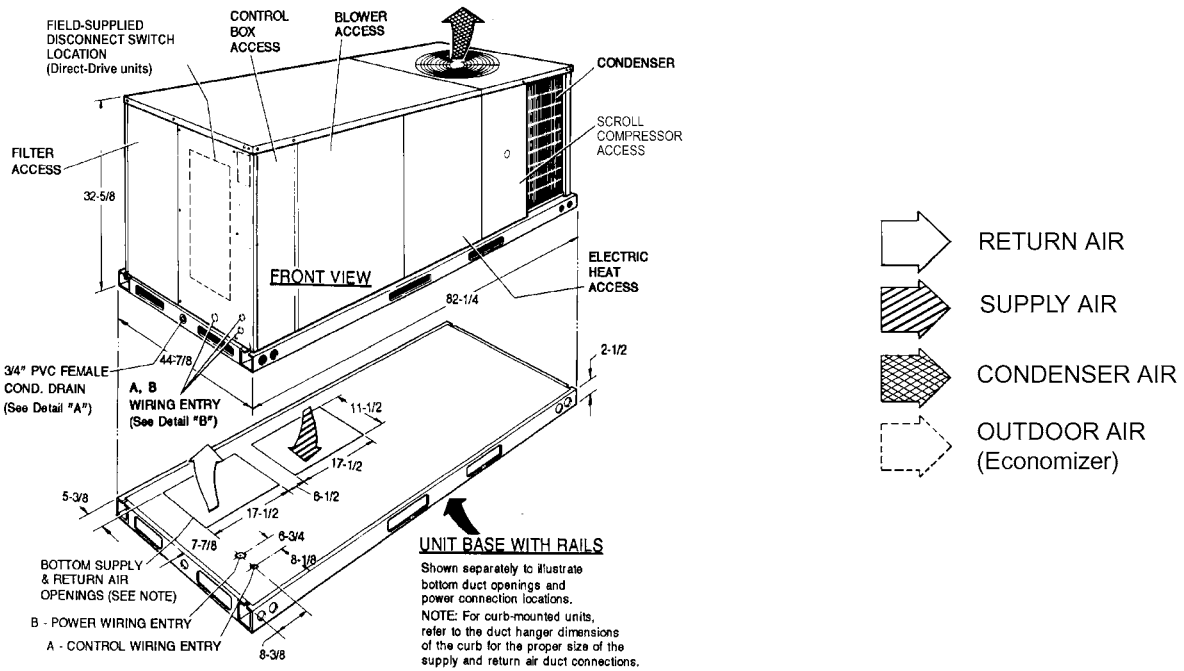

FIGURE 7: UNIT DIMENSIONS (3 - 5 TON HEAT PUMP) FRONT VIEW

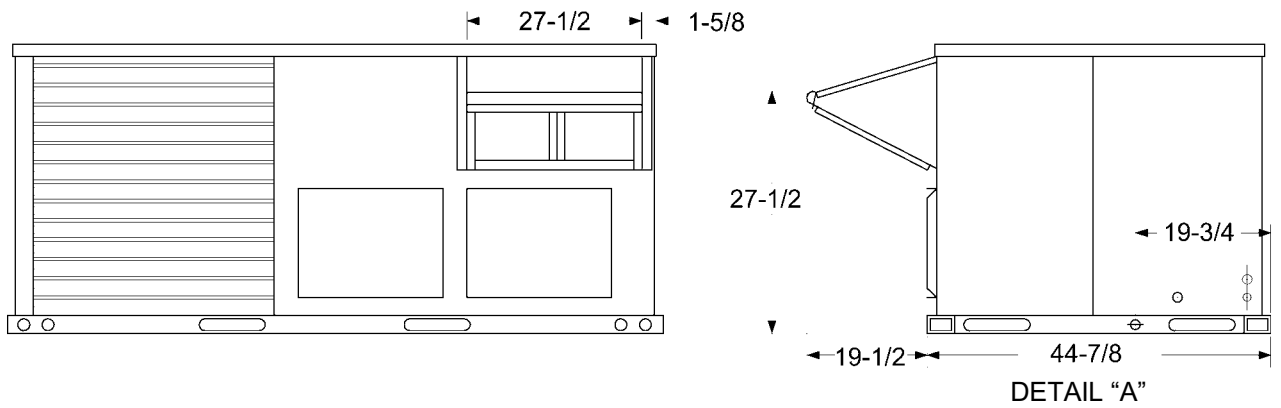

FIGURE 8 - UNIT WITH ECONOMIZER RAINHOOD

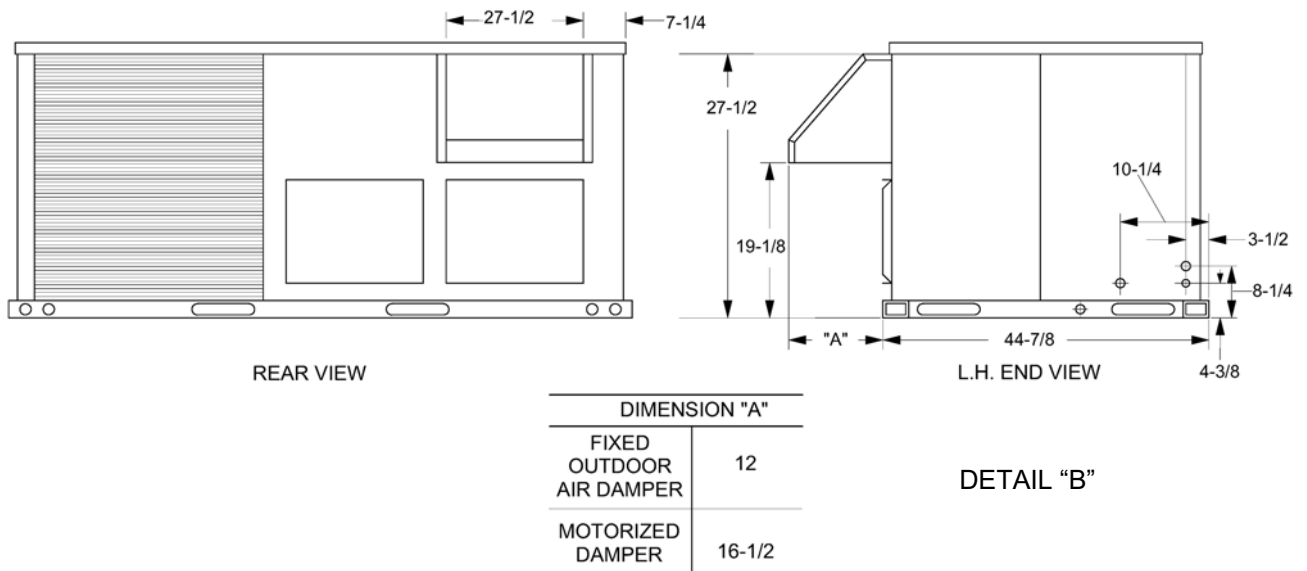
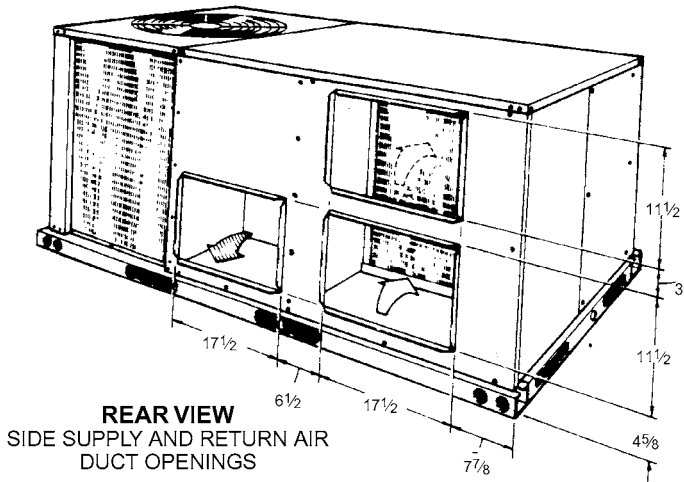

FIGURE 9 - UNIT WITH FIXED OUTDOOR AIR/MOTORIZED DAMPER RAINHOOD



DUCT COVERS - Units are shipped with all air duct openings covered.

For side duct applications;

1. Remove and discard the supply and return air duct covers.
2. Connect ductwork to duct flanges on the rear of the unit.

For bottom duct applications;

1. Remove the side supply air duct cover to gain access to the bottom supply air knockout panel.
2. Remove and discard the bottom knockout panel.
3. Replace the side duct cover.
4. With filter section access panel removed from the unit, remove and discard the bottom return air knockout panel.
5. Replace the filter access panel.

FIGURE 10 - UNIT DIMENSIONS (REAR VIEW)

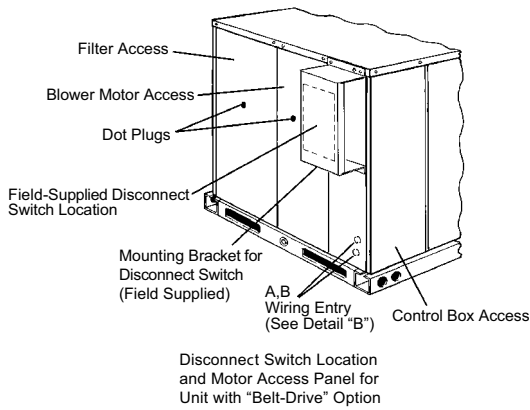

FIGURE 11 - DISCONNECT/BLOWER ACCESS LOCATION

TABLE 18: MINIMUM CLEARANCES

LOCATION	CLEARANCE
Front	24" (Cooling/Electric Heat)
	32" (Gas Heat)
Rear	12" (Less Economizer) 36" (With Economizer or Fixed Air/Motorized Damper)
Left Side (Filter Access)	24" (Less Economizer) 36" (With Economizer)
Right Side (Cond. Coil)	24"
Below Unit ¹	0"
Above Unit ²	72" (For Condenser Air Discharge)

1. Units may be installed on combustible floors made from wood or class A, B, or C roof covering material.
2. Units must be installed outdoors. Overhanging structures or shrubs should not obstruct condenser air discharge outlet.

TABLE 17: UTILITIES ENTRY

HOLE	OPENING SIZE (DIA.)	USED FOR
A	7/8" KO ¹	Control Wiring ²
		Side Bottom
B	2" KO ¹	Power Wiring
		Side Bottom
C	1-5/8" KO	Gas Piping (Front)
D	1-1/2" KO	Gas Piping (Bottom)

1. Opening in the bottom to the unit can be located by the side in the insulation.
2. Do not remove the 2" knockout ring.

TABLE 19: SUPPLY AIR BLOWER PERFORMANCE (BQ036 BELT DRIVE) - SIDE DUCT APPLICATION

Air Flow (CFM)	Available External Static Pressure - IWG ¹																			
	0.2		0.4		0.6		0.8		1.0		1.2		1.4		1.6		1.8		2.0	
	Field Supplied Drive				Standard Drive Option						High Static Drive Option									
800	678	0.37	761	0.44	840	0.52	917	0.60	991	0.69	1062	0.77	1130	0.87	1195	0.96	1259	1.06	1320	1.17
1000	699	0.42	782	0.49	862	0.56	939	0.64	1012	0.73	1083	0.82	1151	0.91	1217	1.01	1280	1.11	1341	1.21
1200	727	0.45	810	0.52	889	0.60	966	0.68	1040	0.76	1110	0.85	1179	0.95	1244	1.04	1308	1.14	1369	1.24
1400	759	0.51	842	0.58	922	0.65	998	0.73	1072	0.82	1143	0.91	1211	1.00	1276	1.10	1340	1.20	1401	1.30
1600	795	0.60	878	0.67	958	0.74	1035	0.82	1108	0.91	1179	1.00	1247	1.09	1313	1.19	1376	1.28	1438	1.39
																				FS ⁴

- Blower performance includes 1" filters. See STATIC RESISTANCE table for additional applications.
- See RPM SELECTION table to determine desired motor sheave setting and to determine the maximum continuous BHP.
- kW = BHP x 0.932.
- Field Supplied Drive.

TABLE 20: SUPPLY AIR BLOWER PERFORMANCE (BQ036 BELT DRIVE) - BOTTOM DUCT APPLICATION

Air Flow (CFM)	Available External Static Pressure - IWG ¹																			
	0.2		0.4		0.6		0.8		1.0		1.2		1.4		1.6		1.8		2.0	
	Field Supplied Drive				Standard Drive Option						High Static Drive Option									
800	661	0.39	751	0.45	838	0.53	922	0.61	1002	0.69	1079	0.78	1153	0.87	1225	0.96	1294	1.06	1361	1.16
1000	685	0.43	775	0.50	862	0.57	945	0.65	1025	0.73	1103	0.82	1177	0.91	1248	1.00	1317	1.10	1384	1.20
1200	714	0.46	805	0.53	892	0.60	975	0.68	1055	0.76	1132	0.85	1207	0.94	1278	1.04	1347	1.13	1414	1.23
1400	749	0.52	840	0.58	927	0.66	1010	0.74	1090	0.82	1167	0.91	1242	1.00	1313	1.09	1382	1.19	1449	1.29
1600	789	0.60	880	0.67	967	0.74	1050	0.82	1130	0.91	1207	0.99	1282	1.08	1353	1.18	1422	1.27	1489	1.37
																				Field Supplied Drive

- Blower performance includes 1" filters. See STATIC RESISTANCE table for additional applications.
- See RPM SELECTION table to determine desired motor sheave setting and to determine the maximum continuous BHP.
- kW = BHP x 0.932.

TABLE 21: SUPPLY AIR BLOWER PERFORMANCE (BQ048 BELT DRIVE) - SIDE DUCT APPLICATION

Air Flow (CFM)	Available External Static Pressure - IWG ¹																			
	0.2		0.4		0.6		0.8		1.0		1.2		1.4		1.6		1.8		2.0	
	Field Supplied Drive				Standard Drive Option						High Static Drive Option									
1000	656	0.41	757	0.46	851	0.52	937	0.58	1017	0.66	1092	0.73	1162	0.81	1228	0.90	1291	0.99	1351	1.08
1200	680	0.47	781	0.52	874	0.58	960	0.65	1041	0.72	1115	0.80	1185	0.88	1251	0.96	1314	1.05	1375	1.14
1400	706	0.56	807	0.61	901	0.67	987	0.73	1067	0.80	1142	0.88	1212	0.96	1278	1.05	1341	1.13	1401	1.22
1600	737	0.67	839	0.72	932	0.77	1018	0.84	1098	0.91	1173	0.99	1243	1.07	1309	1.15	1372	1.24	1433	1.33
1800	774	0.80	875	0.85	968	0.90	1055	0.97	1135	1.04	1209	1.12	1279	1.20	1345	1.28	1408	1.37	1469	1.46
2000	815	0.95	916	1.00	1010	1.06	1096	1.12	1176	1.19	1251	1.27	1321	1.35	1387	1.44	1450	1.52	1510	1.61

- Blower performance includes 1" filters. See STATIC RESISTANCE table for additional applications.
- See RPM SELECTION table to determine desired motor sheave setting and to determine the maximum continuous BHP.
- kW = BHP x 0.932.

TABLE 22: SUPPLY AIR BLOWER PERFORMANCE (BQ048 BELT DRIVE) - BOTTOM DUCT APPLICATION

Air Flow (CFM)	Available External Static Pressure - IWG ¹																			
	0.2		0.4		0.6		0.8		1.0		1.2		1.4		1.6		1.8		2.0	
	Field Supplied Drive				Standard Drive Option						High Static Drive Option									
1000	638	0.42	748	0.47	849	0.53	944	0.59	1031	0.66	1112	0.74	1188	0.82	1260	0.90	1329	0.98	1395	1.07
1200	663	0.48	773	0.53	875	0.59	969	0.65	1056	0.72	1138	0.80	1214	0.88	1286	0.96	1354	1.04	1420	1.13
1400	692	0.57	802	0.61	904	0.67	998	0.73	1085	0.80	1167	0.88	1243	0.96	1315	1.04	1383	1.13	1449	1.21
1600	726	0.67	836	0.72	938	0.78	1032	0.84	1119	0.91	1201	0.98	1277	1.06	1349	1.15	1417	1.23	1483	1.32
1800	766	0.80	876	0.85	977	0.90	1072	0.97	1159	1.04	1240	1.11	1316	1.19	1388	1.27	1457	1.36	1523	1.45
2000	811	0.95	921	0.99	1023	1.05	1117	1.11	1204	1.18	1285	1.26	1362	1.34	1434	1.42	1502	1.51	1568	1.59
																				FS ⁴

- Blower performance includes 1" filters. See STATIC RESISTANCE table for additional applications.
- See RPM SELECTION table to determine desired motor sheave setting and to determine the maximum continuous BHP.
- kW = BHP x 0.932.
- Field Supplied Drive.

TABLE 23: SUPPLY AIR BLOWER PERFORMANCE (BQ060 BELT DRIVE) - SIDE DUCT APPLICATION

Air Flow (CFM)	Available External Static Pressure - IWG ¹																			
	0.2		0.4		0.6		0.8		1.0		1.2		1.4		1.6		1.8		2.0	
	RPM	BHP	RPM	BHP	RPM	BHP	RPM	BHP	RPM	BHP	RPM	BHP	RPM	BHP	RPM	BHP	RPM	BHP	RPM	BHP
	Field Supplied Drive						Standard Drive Option						High Static Drive Option							
1200	680	0.47	781	0.52	874	0.58	960	0.65	1041	0.72	1115	0.80	1185	0.88	1251	0.96	1314	1.05	1375	1.14
1400	706	0.56	807	0.61	901	0.67	987	0.73	1067	0.80	1142	0.88	1212	0.96	1278	1.05	1341	1.13	1401	1.22
1600	737	0.67	839	0.72	932	0.77	1018	0.84	1098	0.91	1173	0.99	1243	1.07	1309	1.15	1372	1.24	1433	1.33
1800	774	0.80	875	0.85	968	0.90	1055	0.97	1135	1.04	1209	1.12	1279	1.20	1345	1.28	1408	1.37	1469	1.46
2000	815	0.95	916	1.00	1010	1.06	1096	1.12	1176	1.19	1251	1.27	1321	1.35	1387	1.44	1450	1.52	1510	1.61
2200	862	1.12	963	1.17	1056	1.23	1142	1.29	1223	1.36	1297	1.44	1367	1.52	1433	1.61	1496	1.70	1557	1.78
2400	913	1.31	1014	1.36	1107	1.42	1194	1.49	1274	1.56	1349	1.63	1419	1.72	1485	1.80	1548	1.89	1608	1.98
2600	969	1.52	1070	1.57	1163	1.63	1250	1.70	1330	1.77	1405	1.84	1475	1.93	1541	2.01	1603	2.10	1664	2.19

1. Blower performance includes 1" filters. See STATIC RESISTANCE table for additional applications.
2. See RPM SELECTION table to determine desired motor sheave setting and to determine the maximum continuous BHP.
3. kW = BHP x 0.932.

TABLE 24: SUPPLY AIR BLOWER PERFORMANCE (BQ060 BELT DRIVE) - BOTTOM DUCT APPLICATION

Air Flow (CFM)	Available External Static Pressure - IWG ¹																			
	0.2		0.4		0.6		0.8		1.0		1.2		1.4		1.6		1.8		2.0	
	RPM	BHP	RPM	BHP	RPM	BHP	RPM	BHP	RPM	BHP	RPM	BHP	RPM	BHP	RPM	BHP	RPM	BHP	RPM	BHP
	Field Supplied Drive						Standard Drive Option						High Static Drive Option							
1200	663	0.48	773	0.53	875	0.59	969	0.65	1056	0.72	1138	0.80	1214	0.88	1286	0.96	1354	1.04	1420	1.13
1400	692	0.57	802	0.61	904	0.67	998	0.73	1085	0.80	1167	0.88	1243	0.96	1315	1.04	1383	1.13	1449	1.21
1600	726	0.67	836	0.72	938	0.78	1032	0.84	1119	0.91	1201	0.98	1277	1.06	1349	1.15	1417	1.23	1483	1.32
1800	766	0.80	876	0.85	977	0.90	1072	0.97	1159	1.04	1240	1.11	1316	1.19	1388	1.27	1457	1.36	1523	1.45
2000	811	0.95	921	0.99	1023	1.05	1117	1.11	1204	1.18	1285	1.26	1362	1.34	1434	1.42	1502	1.51	1568	1.59
2200	861	1.11	971	1.16	1073	1.22	1167	1.28	1255	1.35	1336	1.43	1412	1.51	1484	1.59	1553	1.68	1619	1.76
2400	917	1.30	1027	1.35	1129	1.41	1223	1.47	1311	1.54	1392	1.62	1468	1.69	1540	1.78	1609	1.86	1675	1.95
2600	978	1.51	1088	1.56	1190	1.61	1284	1.68	1371	1.75	1453	1.82	1529	1.90	1601	1.98	1670	2.07	1736	2.15

1. Blower performance includes 1" filters. See STATIC RESISTANCE table for additional applications.
2. See RPM SELECTION table to determine desired motor sheave setting and to determine the maximum continuous BHP.
3. kW = BHP x 0.932.

TABLE 25: SUPPLY AIR BLOWER PERFORMANCE (BQ036, 048 & 060 DIRECT DRIVE) - SIDE DUCT APPLICATION

UNIT TONNAGE	MOTOR ¹ SPEED	AVAILABLE EXTERNAL STATIC PRESSURE - IWG ²																	
		0.2		0.3		0.4		0.5		0.6		0.7		0.8		0.9		1.0	
		CFM	WATTS	CFM	WATTS	CFM	WATTS	CFM	WATTS	CFM	WATTS	CFM	WATTS	CFM	WATTS	CFM	WATTS	CFM	WATTS
3 ³	HI	-	-	-	-	-	-	1720	825	1665	795	1600	765	1540	735	1490	700	1380	670
	MED	1660	850	1630	820	1590	780	1550	750	1500	720	1450	690	1400	665	1360	650	1270	610
	LOW	1470	750	1440	725	1410	700	1370	675	1330	650	1290	625	1250	610	1220	600	1130	560
4 ³	HI	-	-	-	-	2000	1010	1950	975	1905	945	1840	910	1770	825	1660	825	1530	775
	MED	1810	910	1780	880	1740	850	1700	825	1665	800	1620	775	1560	740	1480	700	1390	660
	LOW	1635	810	1610	780	1580	760	1555	740	1540	730	1510	715	1460	690	1400	660	1300	615
5 ³	HI	-	-	-	-	2500	1400	2420	1350	2340	1300	2260	1250	2160	1190	2060	1135	1925	1065
	MED	2390	1350	2350	1300	2300	1255	2245	1210	2190	1165	2130	1120	2065	1075	1990	1030	1900	970
	LOW	2270	1320	2230	1270	2190	1220	2145	1170	2090	1110	2030	1070	1960	1020	1890	970	1810	920

1. Factory set on medium speed tap.
2. Includes allowances for a wet evaporator coil, 1" filters. Refer to STATIC RESISTANCES Table for resistance values.
3. Side Flow application (230/460/575 Volts)

TABLE 26: SUPPLY AIR BLOWER PERFORMANCE (BQ036, 048 & 060 DIRECT DRIVE) - BOTTOM DUCT APPLICATION

UNIT TONNAGE	MOTOR ¹ SPEED	AVAILABLE EXTERNAL STATIC PRESSURE - IWG ²																			
		0.2		0.3		0.4		0.5		0.6		0.7		0.8		0.9		1.0			
		CFM	WATTS	CFM	WATTS	CFM	WATTS	CFM	WATTS	CFM	WATTS	CFM	WATTS	CFM	WATTS	CFM	WATTS	CFM	WATTS		
3 ³	HI	-	-	-	-	-	-	1661	825	1608	795	1545	765	1487	735	1439	700	1333	670		
	MED	1603	850	1574	820	1535	780	1497	750	1449	720	1401	690	1352	665	1314	650	1227	610		
	LOW	1420	750	1391	725	1362	700	1323	675	1285	650	1246	625	1208	610	1179	600	1092	560		
4 ³	HI	-	-	-	-	1931	1010	1882	975	1839	945	1776	910	1709	825	1603	825	1478	775		
	MED	1748	910	1719	880	1680	850	1641	825	1608	800	1564	775	1507	740	1429	700	1343	660		
	LOW	1579	810	1555	780	1526	760	1502	740	1487	730	1458	715	1410	690	1352	660	1256	615		
5 ³	HI	-	-	-	-	2412	1400	2335	1350	2258	1300	2181	1250	2085	1190	1988	1135	1858	1065		
	MED	2306	1350	2268	1300	2220	1255	2167	1210	2114	1165	2056	1120	1993	1075	1921	1030	1834	970		
	LOW	2191	1320	2152	1270	2114	1220	2070	1170	2017	1110	1960	1070	1892	1020	1825	970	1748	920		

1. Factory set on medium speed tap.
2. Includes allowances for a wet evaporator coil, 1" filters. Refer to STATIC RESISTANCES Table for resistance values.
3. Side Flow application (230/460/575 Volts)

TABLE 27: BELT DRIVE RPM SELECTION

Size (Tons)	HP	Max BHP	Motor Sheave	Blower Sheave	5 Turns Open	4 Turns Open	3 Turns Open	2 Turns Open	1 Turn Open	Fully Closed
036 (3)	1.5	1.73	1VL44	AK64	805	865	920	980	1035	1095
	1.5	1.73	1VP56	AK66	1115	1170	1225	1280	1335	1390
048 (4)	1.5	1.73	1VL44	AK56	930	995	1060	1130	1195	1260
	1.5	1.73	1VP56	AK61	1210	1270	1330	1390	1455	1515
060 (5)	1.5	1.73	1VL44	AK56	930	995	1060	1130	1195	1260
	2	2.3	1VP56	AK56	1325	1395	1460	1525	1590	1660

TABLE 28: BELT DRIVE BLOWER MOTOR AND DRIVE DATA

Size (Tons)	Motor					Motor Sheave			Blower Sheave			Belt
	HP	RPM	Eff.	SF	Frame	Datum Dia. (in.)	Bore (in.)	Model	Datum Dia. (in.)	Bore (in.)	Model	
036 (3.0)	1-1/2	1725	0.8	1.15	56	2.8 - 3.8	7/8	1VL44	6.0	1	AK64	A37
	1-1/2	1725	0.8	1.15	56	4.0 - 5.0	7/8	1VP56	6.2	1	AK66	A39
048 (4.0)	1-1/2	1725	0.8	1.15	56	2.8 - 3.8	7/8	1VL44	5.2	1	AK56	A36
	1-1/2	1725	0.8	1.15	56	4.0 - 5.0	7/8	1VP56	5.7	1	AK61	A38
060 (5.0)	1-1/2	1725	0.8	1.15	56	2.8 - 3.8	7/8	1VL44	5.2	1	AK56	A36
	2	1725	0.8	1.15	56	4.0 - 5.0	7/8	1VP56	5.2	1	AK56	A38

TABLE 29: STATIC RESISTANCES

Description	Resistance, IWG											
	CFM											
	1000	1200	1400	1600	1800	2000	2200	2400	2600	2800	3000	
Economizer ^{1 2}	0.07	0.08	0.09	0.11	0.13	0.15	0.17	0.20	0.23	0.26	0.30	
Electric Heaters ¹	7 - 15 kW	0.04	0.05	0.06	0.07	0.08	0.10	0.12	0.14	0.16	0.19	0.22
	20 - 30 kW	0.06	0.07	0.08	0.09	0.11	0.13	0.15	0.17	0.20	0.23	0.26
Bottom Duct Connections ¹	0.06	0.07	0.08	0.09	0.10	0.11	0.12	0.14	0.16	0.19	0.22	

1. Deduct these resistance values from the available external static pressure shown in SUPPLY AIR BLOWER PERFORMANCE Tables.
2. The pressure through the economizer is greater for 100% outdoor air than for 100% return air. If the resistance of the return air duct system is less than 0.25 IWG, the unit will deliver less CFM during full economizer operation.

Drive Selection

1. Determine desired airflow.
2. Calculate or measure the amount of external static pressure.
3. Using the operating point determined from steps 1 & 2, locate this point on the appropriate supply air blower performance table. (Linear interpolation may be necessary.)
4. Noting the RPM and BHP from step 3, locate the appropriate model and drive on the RPM selection table.
5. Review the BHP compared to the motor options available. Select the appropriate motor.
6. Review the RPM range for the motor options available. Select the appropriate drive if multiple drives are available for the chosen motor.
7. Determine turns open to obtain the desired operation point.

Example

1. 19000 CFM
2. 5.4 iwg
3. Using the supply air blower performance table below, the following data point was located: 1150 RPM & 36 BHP.
4. Using the RPM selection table below, Size X and Model Y is found.
5. 36 BHP exceeds the maximum continuous BHP rating of the 30 HP motor. The 40 HP motor is required.
6. 1150 RPM is within the range of the 30 & 40 HP drives, but step 5 requires the 40 HP motor.
7. Using the 40 HP motor and drive, 5.5 turns open will achieve 1150 RPM.

Example Supply Air Blower Performance

Air Flow (CFM)	Available External Static Pressure - IWG																			
	3.0		3.4		3.8		4.2		4.6		5.0		5.4		5.8		6.2		6.6	
	RPM	BHP	RPM	BHP	RPM	BHP	RPM	BHP	RPM	BHP	RPM	BHP	RPM	BHP	RPM	BHP	RPM	BHP	RPM	BHP
	30 HP & Field Supplied Drive						Standard 30 HP & Drive						Alternate 40 HP & Drive							
18000	800	10.00	850	14.00	900	18.00	950	22.00	1000	26.00	1050	30.00	1100	34.00	1150	38.00	1200	42.00	1250	46.00
19000	850	12.00	900	16.00	950	20.00	1000	24.00	1050	28.00	1100	32.00	1150	36.00	1200	40.00	1250	44.00	1300	48.00
20000	900	14.00	950	18.00	1000	22.00	1050	26.00	1100	30.00	1150	34.00	1200	38.00	1250	42.00	1300	46.00	1350	50.00
21000	950	16.00	1000	20.00	1050	24.00	1100	28.00	1150	32.00	1200	36.00	1250	40.00	1300	44.00	1350	48.00	1400	52.00

Table X: RPM Selection

Size (Tons)	Model	HP	Max BHP	Motor Sheave	Blower Sheave	6 Turns Open	5 Turns Open	4 Turns Open	3 Turns Open	2 Turns Open	1 Turn Open	Fully Closed
X	Y	30	34.50	1VL51	BK99	1000	1025	1045	1060	1110	1150	N/A
		40	46.00	1VL63	BK67	1125	1175	1250	1325	1400	1475	N/A

Altitude/Temperature Correction Factors

Air Temp.	Altitude (Ft.)										
	0	1000	2000	3000	4000	5000	6000	7000	8000	9000	10000
40	1.060	1.022	0.986	0.950	0.916	0.882	0.849	0.818	0.788	0.758	0.729
50	1.039	1.002	0.966	0.931	0.898	0.864	0.832	0.802	0.772	0.743	0.715
60	1.019	0.982	0.948	0.913	0.880	0.848	0.816	0.787	0.757	0.729	0.701
70	1.000	0.964	0.930	0.896	0.864	0.832	0.801	0.772	0.743	0.715	0.688
80	0.982	0.947	0.913	0.880	0.848	0.817	0.787	0.758	0.730	0.702	0.676
90	0.964	0.929	0.897	0.864	0.833	0.802	0.772	0.744	0.716	0.689	0.663
100	0.946	0.912	0.880	0.848	0.817	0.787	0.758	0.730	0.703	0.676	0.651

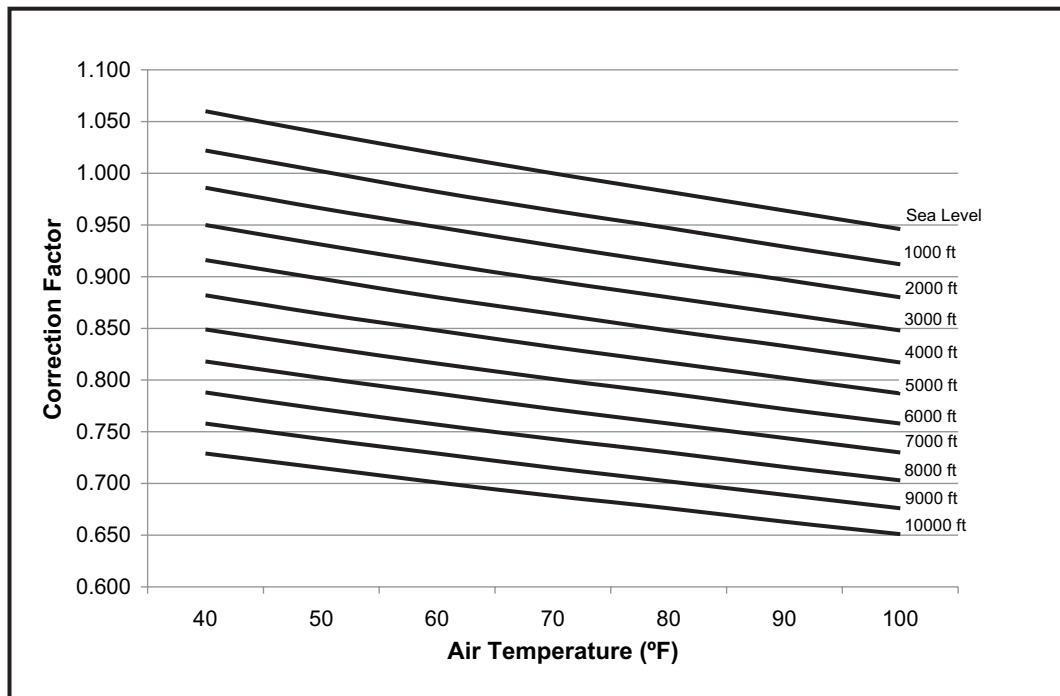

PHASING

Check for proper compressor rotation. If the blower or compressors rotate in the wrong direction at start-up, the electrical connection to the unit is misphased. Change the incoming line connection phasing to obtain proper rotation. (Scroll compressors operate in only one direction. If the scroll is drawing low amperage, has similar suction and discharge pressures, or producing a high noise level, the scroll is misphased).

CAUTION

Scroll compressors require proper rotation to operate correctly. Do not change the internal wiring to make the blower, condenser fans, or compressor rotate correctly. Change the incoming power to the main terminal block to obtain proper rotation.

SUPPLY AIR BLOWERS

These blowers have either 3-speed direct drive motors, or single speed motors equipped with a belt drive. Belt drive units have a variable pitch motor pulley that allows the blower speed to be adjusted.

CHECKING SUPPLY AIR CFM

The RPM of the supply air blower will depend on the required CFM, the unit accessories or options and the static resistances of both the supply and the return air duct systems. With this information, the motor speed tap (direct drive) or the motor pulley number of turns open (belt drive) can be determined from the Blower Performance Data Tables.

Note the following:

1. The supply air CFM must be within the limitations shown in the Unit Application Data Table 1.
2. Pulleys can be adjusted in half turn increments.
3. The tension on the belt should be adjusted as shown in the Belt Adjustment Figure 12.

PROCEDURE FOR ADJUSTING BELT TENSION:

1. Loosen nuts (A) (top and bottom).
2. Adjust the tension by turning bolt (B).
3. Never loosen nuts (C) from each other.
4. Use a belt tension checker to apply a perpendicular force to be one belt at the midpoint of the span as shown. The deflection force should be applied until a specific deflection distance of 4mm (5/32") is obtained. To determine the deflection distance from normal position, use a straight edge from sheave to sheave as a reference line. The recommended deflection force is as follows:

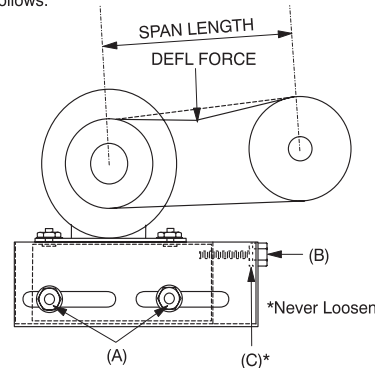

Tension new belts at the max. deflection force recommended for the belt section. Check the belt tension at least two times during the first 24 hours of operation. Any re-tensioning should fall between the min. and max. deflection force values.

5. After adjusting, re-tighten nuts (A).

FIGURE 12 - BELT ADJUSTMENT

Start the supply air blower motor. Adjust the resistances in both the supply and the return air duct systems to balance the air distribution throughout the conditioned space. The job specifications may require that this balancing be done by someone other than the equipment installer.

To check the supply air CFM after the initial balancing has been completed:

1. Remove the two 5/16" dot plugs from the blower motor and the filter access panels shown in Figure 11.
2. Insert at least 8" of 1/4 inch tubing into each of these holes for sufficient penetration into the air flow on both sides of the indoor coil.

NOTE: The tubes must be inserted and held in a position perpendicular to the air flow so that velocity pressure will not affect the static pressure readings.

3. Using an inclined manometer, determine the pressure drop across a dry evaporator coil. Since the moisture on an evaporator coil may vary greatly, measuring the pressure drop across a wet coil

under field conditions would be inaccurate. To assure a dry coil, the compressors should be deactivated while the test is being run.

- Knowing the pressure drop across a dry coil, the actual CFM through the unit can be determined from the curve in Pressure Drop vs. Supply Air CFM (Figure 13).

▲WARNING
Failure to properly adjust the total system air quantity and static pressure can result in extensive system damage.

After readings have been obtained, remove the tubes and reinstall the two 5/16" dot plugs that were removed in Step 1.

NOTE: De-energize the compressors before taking any test measurements to assure a dry indoor coil.

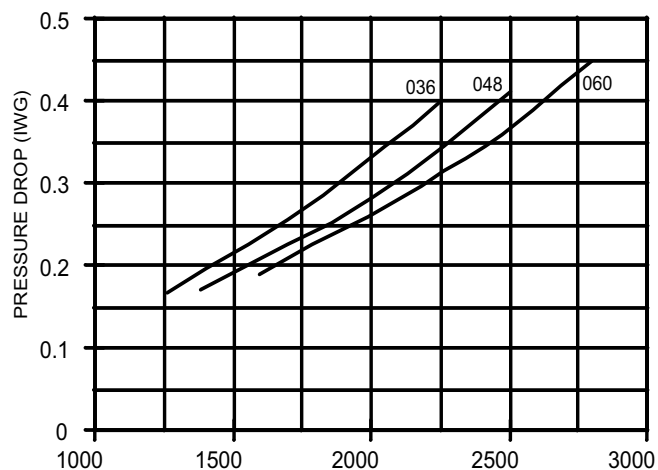

FIGURE 13 - PRESSURE DROP ACROSS COIL

OPERATION

SEQUENCE OF OPERATIONS OVERVIEW

For these units, the thermostat makes a circuit between "R" and "Y1" for the cooling cycle.

The call is passed to the unit control board (UCB), which then determines whether the requested operation is available and, if so, which components to energize.

For heating, the thermostat makes a circuit between "R" and "W1". The UCB energizes the compressor and condenser fan allowing the unit to run in heating mode. A time / temperature control operates the defrost cycle.

If at any time a call for both heating and cooling are present, the heating operation will be performed. If operating, the cooling system is halted as with a completion of a call for cooling. Heating always takes priority.

COOLING SEQUENCE OF OPERATION

CONTINUOUS BLOWER

By setting the room thermostat fan switch to "ON," the supply air blower will operate continuously.

INTERMITTENT BLOWER

With the room thermostat fan switch set to "AUTO" and the system switch set to either the "AUTO" or "HEAT" settings, the blower is energized whenever a cooling or heating operation is requested. The blower is energized after any specified delay associated with the operation.

When energized, the indoor blower has a minimum run time of 30 seconds. Additionally, the indoor blower has a delay of 10 seconds between operations.

NO OUTDOOR AIR OPTIONS

When the thermostat calls for cooling, the low-voltage control circuit from "R" to "Y1" and "G" is completed. The compressor and condenser fan motor are energized. After completing the specified fan on delay for cooling, the UCB will energize the blower motor.

Once the thermostat has been satisfied, it will de-energize Y1. If the compressor has satisfied its minimum run time, the compressor and condenser fan de-energize. Otherwise, the unit operates the cooling system until the minimum run time for the compressor has been completed. After the compressor de-energizes, the blower is stopped following the elapse of the fan off delay for cooling.

To be available, a compressor must not be locked-out due to a high or low-pressure switch or freezestat trip and the anti-short cycle delay (ASCD) must have elapsed.

ECONOMIZER WITH SINGLE ENTHALPY SENSOR -

When the room thermostat calls for cooling, the low voltage control circuit from “R” to “G” and “Y1” is completed. The UCB energizes the blower motor (if the fan switch on the room thermostat is set in the “AUTO” position) and drives the economizer dampers from fully closed to their minimum position. If the enthalpy of the outdoor air is below the setpoint of the enthalpy controller (previously determined), “Y1” energizes the economizer. The dampers will modulate to maintain a constant supply air temperature as monitored by the discharge air sensor. If the outdoor air enthalpy is above the setpoint, “Y1” energizes the compressor and condenser fan motor only.

Once the thermostat has been satisfied, it will de-energize “Y1”. If the compressor has satisfied its minimum run time, the compressor and condenser fan are de-energized. Otherwise, the unit operates the cooling system until the minimum run times for the compressor has been completed. After the compressor de-energizes, the blower is stopped following the elapse of the fan off delay for cooling, and the economizer damper goes to the closed position. If the unit is in continues fan operation the economizer damper goes to the min. position.

ECONOMIZER WITH DUAL ENTHALPY SENSORS -

The operation with the dual enthalpy sensors is identical to the single sensor except that a second enthalpy sensor is mounted in the return air. This return air sensor allows the economizer to choose between outdoor air and return air, whichever has the lowest enthalpy value, to provide maximum operating efficiency.

ECONOMIZER (SINGLE OR DUAL) WITH POWER EXHAUST -

This system operates as specified above with one addition. The power exhaust motor is energized 45 seconds after the actuator position exceeds the exhaust fan setpoint on the economizer control. When the power exhaust is operating, the second stage of mechanical cooling will not operate. As always, the “R” to “G” connection provides minimum position but does not provide power exhaust operation.

MOTORIZED OUTDOOR AIR DAMPERS -

This system operation is the same as the units with no outdoor air options with one exception. When the “R” to “G” circuit is complete, the motorized damper drives

open to a position set by the thumbwheel on the damper motor. When the “R” to “G” circuit is opened, the damper spring returns fully closed.

COOLING OPERATION ERRORS

Each cooling system is monitored for operation outside of the intended parameters. Errors are handled as described below. All system errors override minimum run times for compressors.

HIGH-PRESSURE LIMIT SWITCH

During cooling operation, if a high-pressure limit switch opens, the UCB will de-energize the compressor, initiate the ASCD (Anti-short cycle delay), and, stop the condenser fan. If the call for cooling is still present at the conclusion of the ASCD, the UCB will re-energize the compressor.

Should a high-pressure switch open three times within two hours of operation, the UCB will lock-out the compressor and flash a code (see Table 32).

LOW-PRESSURE LIMIT SWITCH

The low-pressure limit switch is not monitored during the initial 30 seconds of a cooling system's operation. For the following 30 seconds, the UCB will monitor the low-pressure switch to ensure it closes. If the low-pressure switch fails to close after the 30-second monitoring phase, the UCB will de-energize the compressor, initiate the ASCD, and stop the condenser fan.

Once the low-pressure switch has been proven (closed during the 30-second monitor period described above), the UCB will monitor the low-pressure limit switch for any openings. If the low-pressure switch opens for greater than 5 seconds, the UCB will de-energize the compressor, initiate the ASCD, and stop the condenser fan.

If the call for cooling is still present at the conclusion of the ASCD, the UCB will re-energize the compressor.

Should a low-pressure switch open three times within one hour of operation, the UCB will lock-out the compressor and flash a code (see Table 32).

FREEZESTAT

During cooling operation, if a freezestat opens, the UCB will de-energize the compressor, initiate the ASCD, and stop the condenser fan. If the call for cool-

ing is still present at the conclusion of the ASCD, the UCB will re-energize the compressor.

Should a freezestat open three times within two hours of operation, the UCB will lock-out the compressor and flash a code (see Table 32).

LOW AMBIENT COOLING

To determine when to operate in low ambient mode, the UCB has a pair of terminals connected to a temperature-activated switch set at 45°F. When the low ambient switch is closed and the thermostat is calling for cooling, the UCB will operate in the low ambient mode.

Low ambient mode operates the compressors in this manner: 10 minutes on, 5 minutes off. The indoor blower is operated throughout the cycle. The 5-minute off period is necessary to defrost the indoor coil.

Low ambient mode always begins with compressor operation. Compressor minimum run time may extend the minutes of compressor operation. The defrost cycle will begin immediately following the elapse of the minimum run time.

When operating in low ambient mode, the UCB will not lockout the compressor due to a freezestat trip. However, a freezestat trip will de-energize the compressor. If the call for cooling is still present at the end of the ASCD and the freezestat has closed, the unit will resume operation.

SAFETY CONTROLS

The unit control board monitors the following inputs for the cooling system:

1. A suction line freezestat to protect against low evaporator temperatures due to a low airflow or a low return air temperature, (opens at 26 ± 5 °F and resets at 38 ± 5 °F).
2. A high-pressure switch to protect against excessive discharge pressures due to a blocked condenser coil or a condenser motor failure, (opens at 380 ± 10 psig and resets at 300 ± 10 psig).
3. A low-pressure switch to protect against loss of refrigerant charge, (opens at 7 ± 3 psig and resets at 22 ± 5 psig).

The above pressure switches are hard-soldered to the unit. The refrigeration system is monitored and con-

trolled. On any fault, the system will be affected by any safety/preventive action.

The unit control board monitors the temperature limit switch of the electric heat.

COMPRESSOR PROTECTION

The compressor also has inherent (internal) protection. If there is an abnormal temperature rise in a compressor, the protector will open to shut down the compressor. The UCB incorporates features to minimize compressor wear and damage. An anti-short cycle delay (ASCD) is utilized to prevent operation of a compressor too soon after its previous run. Additionally, a minimum run time is imposed any time a compressor is energized.

The ASCD is initiated on unit start-up and on any compressor reset or lock-out.

FLASH CODES

The UCB will initiate a flash code associated with errors within the system. Refer to UNIT CONTROL BOARD FLASH CODES Table 32.

RESET

Remove the call for cooling, by raising thermostat setting higher than the conditioned space temperature. This resets any pressure or freezestat flash codes.

HEATING SEQUENCE OF OPERATIONS

WITH OR WITHOUT ELECTRIC HEAT

When the thermostat calls for the first stage of heating, the low voltage control circuit is completed between "R" and "W1". The 24vac signal is passed through the UCB to the "Y" contact on the Defrost Control (DC) assuring the reversing valve cannot be energized, except during defrost. If the ASCD timer is satisfied the UCB will energize compressor contactor M1.

If the compressor alone cannot satisfy the heating requirements, a second stage call from the thermostat completes the circuit between "R" and "W2". This 24vac signal is passed through the UCB to the electric heat section (if available). The total available kW of electric heat will be energized on a call for "W2".

DEFROST MODE

As mentioned earlier, the defrost control (DC) utilizes a time/temperature defrost scheme. The following two conditions must be met before the DC will enter a defrost mode:

The defrost thermostat (SD) must be closed. This normally open thermostat is mounted on the liquid line and is set to close at $28 \pm 4^\circ\text{F}$.

Once the defrost thermostat closes, the defrost control starts a run timer that must be satisfied before defrost can begin. This is accumulated compressor run time. The selection pin is factory set at 60 minutes, but is field adjustable to 30, 60 or 90 minutes.

When the DC enters the defrost mode, it's on-board defrost relay is powered. This energizes the reversing valve, de-energizes the condenser fan motor and energizes the unit's optional electric heater. The DC remains in defrost mode until either of the following two conditions is met:

1. The liquid line thermostat is open. It is set to open at $55 \pm 4^\circ\text{F}$.
2. The maximum defrost run time of 10 minutes is met.

FORCED DEFROST

The processor on the defrost board is only energized when the defrost sensor (DS) is closed.

To create a forced defrost:

1. The DS must either be closed or a jumper must be placed across the DFS terminals on the board.
2. Place a jumper across the test pin terminals on the board.

Depending on the selected defrost minimum run time of 30, 60 or 90 minutes, the board will go into defrost in 7.5, 15 or 22.5 seconds.

The DC will remain in defrost until the jumpers across the DS and the test pin terminals are removed.

Once the jumpers are removed, the board then terminates defrost when the DS opens or a maximum of 10 minutes after the test pin jumper is removed, whichever comes first.

SAFETY CONTROLS

The control circuit includes the following safety controls:

1. Temperature Limit Switch (TLS) - This control is located inside the heater compartment and is set to open at the temperature indicated in the Electric Heat Limit Control Setting Table 30. It resets automatically. The limit switch operates when a high temperature condition, caused by inadequate supply air flow occurs, thus shutting down the heater and energizing the blower.

TABLE 30: ELECTRIC HEAT LIMIT CONTROL SETTING

VOLTAGE	kW	TEMPERATURE LIMIT SWITCH	Open Temp °F	
230-1-60	5	1	140	
	7	1,3	140	
	10	1,2,3	140	
	15	2,4,6	140	
	20	30	1,2,3,4,5	140
			6	150
230-3-60	5	1,2,3	140	
		1,2,3	140	
	10	1,2,3	150	
		2,4,6	140	
	20	1,2,3,4,5,6	150	
		30	1,3,5	160
	2,4,6		150	
460-3-60	7	2,4,6	140	
		2,4,6	140	
	15	2,4,6	140	
		3	160	
	30	3	150	
575-3-60	10	2,4,6	140	
		2,4,6	140	
	20	5	160	
		5	150	

HEAT ANTICIPATOR SETPOINTS

It is important that the anticipator setpoint be correct. Too high of a setting will result in longer heat cycles and a greater temperature swing in the conditioned space. Reducing the value below the correct setpoint will give shorter "ON" cycles and may result in the lowering of the temperature within the conditioned space.

Refer to Table 31 for the required electric heat anticipator setting.

TABLE 31: ELECTRIC HEAT ANTICIPATOR SETPOINTS

HEATER KW	VOLTAGE	SETTING, AMPS	
		TH1	TH2
5	230-3-60	0.024	0.35
7		0.024	0.35
10		0.024	0.35
15		0.024	0.35
20		0.024	0.35
30		0.024	0.35
7	460-3-60	0.024	0.35
10		0.024	0.35
15		0.024	0.35
20		0.024	0.37
30		0.024	0.37
10	575-3-60	0.024	0.35
15		0.024	0.35
20		0.024	0.37
30		0.024	0.37

START-UP (COOLING)

PRESTART CHECK LIST

After installation has been completed:

- Check the electrical supply voltage being supplied. Be sure that it is the same as listed on the unit nameplate.
- Set the room thermostat to the off position.
- Turn unit electrical power on.
- Set the room thermostat fan switch to on.
- Check indoor blower rotation.
 - If blower rotation is in the wrong direction. Refer to Phasing Section in general information section.
 - Check blower drive belt tension.
- Check the unit supply air (CFM). See "CHECKING SUPPLY AIR CFM" on page 30.
- Measure evaporator fan motor's amp draw.
- Set the room thermostat fan switch to off.
- Turn unit electrical power off.

OPERATING INSTRUCTIONS

- Turn unit electrical power on.
- Set the room thermostat setting to lower than the room temperature.

- Compressor will energize after the built-in time delay (five minutes).

POST START CHECK LIST

- Verify proper system pressures.
- Measure the temperature drop across the evaporator coil.
- Measure the system Amperage draw across all legs of 3 phase power wires.
- Measure the condenser fan amp draw.

SHUT DOWN

- Set the thermostat to highest temperature setting.
- Turn off the electrical power to the unit.

TROUBLESHOOTING

COOLING TROUBLESHOOTING GUIDE

WARNING

Troubleshooting of components may require opening the electrical control box with the power connected to the unit. **Use extreme care when working with live circuits!** Check the unit nameplate for the correct line voltage and set the voltmeter to the correct range before making any connections with line terminals.

When not necessary, shut off all electric power to the unit prior to any of the following maintenance procedures so as to prevent personal injury.

CAUTION

Label all wires prior to disconnection when servicing controls. Wiring errors can cause improper and dangerous operation, which could cause injury to person and/or damage unit components. Verify proper operation after servicing.

On calls for cooling, if the compressors are operating but the supply air blower motor does not energize after a short delay (the room thermostat fan switch is in the "AUTO" position).

- Turn the thermostat fan switch to the ON position. If the supply air blower motor does not energize, go to Step 3.
- If the blower motor runs with the fan switch in the ON position but will not run after the compressor

has energized when the fan switch is in the AUTO position, check the room thermostat for contact between R and G in the AUTO position during calls for cooling.

3. If the supply air blower motor does not energize when the fan switch is set to ON, check that line voltage is being supplied to the contacts of the M2, contactor, and that the contactor is pulled in. Check for loose wiring between the contactor and the supply air blower motor.
4. If M2 is pulled in and voltage is supplied to M2, lightly touch the supply air blower motor housing. If it is hot, the motor may be off on internal protection. Cancel any thermostat calls and set the fan switch to AUTO. Wait for the internal overload to reset. Test again when cool.
5. If M2 is not pulled in, check for 24 volts at the M2 coil. If 24 volts are present at M2 but M2 is not pulled in, replace the contactor.
6. Failing the above, if there is line voltage supplied at M2, M2 is pulled in, and the supply air blower motor still does not operate, replace the motor.
7. If 24 volts is not present at M2, check that 24 volts is present at the UCB supply air blower motor terminal, "FAN". If 24 volts is present at the FAN, check for loose wiring between the UCB and M2.
8. If 24 volts is not present at the "FAN" terminal, check for 24 volts from the room thermostat. If 24 volts are not present from the room thermostat, check for the following:
 - a. Proper operation of the room thermostat (contact between R and G with the fan switch in the ON position and in the AUTO position during operation calls).
 - b. Proper wiring between the room thermostat and the UCB.
 - c. Loose wiring from the room thermostat to the UCB.
9. If 24 volts is present at the room thermostat but not at the UCB, check for proper wiring between the thermostat and the UCB, i.e. that the thermostat G terminal is connected to the G terminal of the UCB, and for loose wiring.
10. If the thermostat and UCB are properly wired, replace the UCB.

On a call for cooling, the supply air blower motor is operating but the compressor is not (the room thermostat fan switch is in the "AUTO" position).

1. If installed, check the position of the economizer blades. If the blades are open, the economizer is

providing free cooling and the compressors will not immediately operate. If both stages of cooling are requested simultaneously and the economizer provides free cooling, following a short delay the compressor will be energized unless it is locked out, unless this option has been disabled through computer communications.

2. If no economizer is installed or the economizer is not opening to provide free cooling and the compressor does not energize on a call for cooling, check for line voltage at the compressor contactor, M1, and that the contactor is pulled in. Check for loose wiring between the contactor and the compressor.
3. If M1 is pulled in and voltage is supplied at M1, lightly touch the compressor housing. If it is hot, the compressor may be off on inherent protection. Cancel any calls for cooling and wait for the internal overload to reset. Test again when cool.
4. If M1 is not pulled in, check for 24 volts at the M1 coil. If 24 volts are present and M1 is not pulled in, replace the contactor.
5. Failing the above, if voltage is supplied at M1, M1 is pulled in, and the compressor still does not operate, replace the compressor.
6. If 24 volts is not present at M1, check for 24 volts at the UCB terminal, C1. If 24 volts is present, check for loose wiring between C1 and the compressor contactor.
7. If 24 volts is not present at the C1 terminal, check for 24 volts from the room thermostat at the UCB Y1 terminal. If 24 volts is not present from the room thermostat, check for the following:
 - a. 24 volts at the thermostat Y1 terminal
 - b. Proper wiring between the room thermostat and the UCB, i.e. Y1 to Y1, Y2 to Y2
 - c. Loose wiring from the room thermostat to the UCB.
8. If 24 volts is present at the UCB Y1 terminal, the compressor may be out due to an open high-pressure switch, low-pressure switch, or freestat. Check for 24 volts at the HPS1, LPS1, and FS1 terminals of the UCB. If a switch has opened, there should be a voltage potential between the UCB terminals, e.g. if LPS1 has opened, there will be a 24-volt potential between the LPS1 terminals.
9. If 24 volts is present at the UCB Y1 terminal and none of the protection switches have opened, the UCB may have locked out the compressor for repeat trips. The UCB should be flashing an alarm code. If not, press and release the ALARMS button on the UCB.

The UCB will flash the last five alarms on the LED. If the compressor is locked out, cancel any call for cooling. This will reset any compressor lock outs.

NOTE: While the above step will reset any lockouts, the compressor may be held off for the ASCD. See the next step.

10. If 24 volts is present at the UCB Y1 terminal and none of the switches are open and the compressor is not locked out, the UCB may have the compressor in an ASCD. Check the LED for an indication of an ASCD cycle. The ASCD should time out within 5 minutes. Press and release the TEST button to reset all ASCDs.
11. If 24 volts is present at the UCB Y1 terminal and the compressor is not out due to a protective switch trip, repeat trip lock out, or ASCD, the economizer terminals of the UCB may be improperly wired. Check for 24 volts at the Y1 "OUT" terminal of the UCB. If 24 volts is present, trace the wiring from Y1 "OUT" for incorrect wiring. If 24 volts is not present at the Y1 "OUT" terminal, the UCB must be replaced.
12. *For units without economizers:* If 24 volts is present at the Y1 OUT terminal, check for 24 volts at the Y1 "ECON" terminal. If 24 volts is not present, check for loose wiring from the Y1 "OUT" terminal to the Mate-N-Lock plug, the jumper in the Mate-N-Lock plug, and in the wiring from the Mate-N-Lock plug to the Y1 "ECON" terminal.
13. *For units with economizers:* If 24 volts is present at the Y1 "OUT" terminal, check for 24 volts at the Y1 "ECON" terminal. If 24 volts is not present, check for loose wiring from the Y1 "OUT" terminal to the Mate-N-Lock plug, a poor connection between the UCB and economizer Mate-N-Lock plugs, loose wiring from the Mate-N-Lock plug to the economizer, back to the Mate-N-Lock plug, and from the Mate-N-Lock plug to the Y1 "ECON" terminal. If nothing is found, the economizer actuator may have faulted and is failing to return the 24-volt "call" to the Y1 "ECON" terminal even though the economizer is not providing free cooling. To test, disconnect the Mate-N-Locks and jumper between the WHITE and YELLOW wires of the UCB's Mate-N-Lock plug. If the compressor energizes, there is a fault in the economizer wiring or actuator.
14. The UCB can be programmed to lock out compressor operation during free cooling and in low ambient conditions. These options are not enabled by default. Local distributors can test the UCB for this programming.

For units with factory installed economizers, the UCB is programmed to lock out compressor operation when the LAS set point is reached.

For units without factory installed or with field installed economizers, the UCB allows compressor operation all the time. This programming can be checked or changed by the local distributor.

15. If none of the above correct the error, replace the UCB.

UNIT FLASH CODES

Various flash codes are utilized by the unit control board (UCB) to aid in troubleshooting. Flash codes are distinguished by the short on and off cycle used (approximately 200ms on and 200ms off). To show normal operation, the control board flashes a 1 second on, 1 second off "heartbeat" during normal operation. This is to verify that the UCB is functioning correctly. Do not confuse this with an error flash code. To prevent confusion, a 1-flash, flash code is not used.

Current alarms are flashed on the UCB LED. Pressing and releasing the ALARMS button on the UCB can check the alarm history. The UCB will cycle through the last five (5) alarms, most recent to oldest, separating each alarm flash code by approximately 2 seconds.

In some cases, it may be necessary to "zero" the ASCD for the compressors in order to perform troubleshooting. To reset all ASCDs for one cycle, press and release the UCB TEST button once.

TABLE 32: UNIT CONTROL BOARD FLASH CODES

Flash Code	Description
On Steady	Control Failure - Replace Control
Heart Beat	Normal Operation
1 Flash	Not Applicable
2 Flashes	Control waiting ASCD ¹
3 Flashes	HPS1 - Compressor Lock out
5 Flashes	LPS1 - Compressor Lock out
7 Flashes	FS1 - Compressor Lock out
9 Flashes	Ignition Control Locked Out/ Ignition Control Failure / Limit Switch Trip / No Jumper Plug in Heat Section
10 Flashes	Compressors Locked Out On Low Outdoor Air Temperature ¹
11 Flashes	Compressors Locked Out Because the Economizer Is Using Free Cooling ¹
13 Flashes	Compressor Held Off Due To Low Voltage ¹
14 Flashes	EEPROM Storage Failure (Control Failure)
OFF	No Power or Control Failure

1. These flash codes do not represent alarms.

MAINTENANCE

NORMAL MAINTENANCE

CAUTION

Prior to any of the following maintenance procedures, shut off all electric power to the unit to prevent personal injury.

FILTERS

Inspect once a month. Replace disposable or clean permanent type as necessary. DO NOT replace permanent type with disposable. The dimensional size of the replacement filter must be the same as the replaced filter.

MOTORS

Outdoor fan motors are permanently lubricated and require no maintenance.

Indoor Blower Motor and Drive - The indoor blower motor features ball bearings that do not require periodic lubrication. Periodic lubrication of the motor and bearings can extend the life of components but is optional.

CAUTION

Damage can occur if the bearings are overlubricated. Use grease sparingly.

WARNING

Perform all maintenance operations on the blower motor with electric power disconnected from the unit. Do not attempt to lubricate bearings with the unit in operation.

On an annual basis, check the motor for accumulations of dust, etc. that may block the cooling slots in the motor shell. Check for loose, damaged or misaligned drive components. Check that all mounting bolts are tight. Replace defective parts as required.

If desired, every three years remove both pipe plugs at each end shell and clean out any hardened grease or foreign matter. Replace one plug on each end with a clean grease fitting. Using a low pressure grease gun, pump grease (Chevron SRI-2 or equivalent) into the bearing cavity until new grease shows at the open port. Do not over lubricate. Run the motor for ten minutes until excess grease is purged from the cavity. Replace the plugs.

15 ton units are supplied with blower shaft bearings that do not require maintenance but may be lubricated if desired. Every three years, using a low pressure grease gun, pump grease into the bearing grease fitting until grease just begins to show at the seals. Do not over lubricate. Use any lithium base grease recommended for ball bearing service.

OUTDOOR COIL

Dirt should not be allowed to accumulate on the outdoor coil surface or other parts in the air circuit. Cleaning should be as often as necessary to keep coil clean. Use a brush, vacuum cleaner attachment, or other suitable means. If water is used to clean coil, be sure electric power to the unit is shut off prior to cleaning.

NOTE: Exercise care when cleaning the coil so that the coil fins are not damaged.

